



Ocel, ktorá hreje

Ocelové panelové radiátory
KORAD

V ý r o b n ý p r o g r a m

KORAD
10
ROKOV
ZÁRUKA



U. S. STEEL KOŠICE, s.r.o. - VÝROBCA OCEĽOVÝCH PANELOVÝCH RADIÁTOROV KORAD
SPOLOČNOSŤ

U. S. Steel Košice, s.r.o. je dcérskou firmou korporácie U. S. Steel so sídlom v Pittsburgu, USA. Korporácia sa už vyše sto rokov zaoberá výrobou a spracovaním ocele a patrí k najväčším svetovým výrobcam.

Spoločnosť U. S. Steel Košice, s.r.o. je jedným z najvýznamnejších výrobcov plochých valcovaných výrobkov v strednej Európe. Tento moderný integrovaný hutnícky podnik zahŕňa procesy od spracovania primárnych nerastných surovín cez výrobu surového železa a ocele až po výstupy finálnych produktov s vysokou pridanou hodnotou. Jej výrobný program pozostáva zo širokej škály plechov valcovaných za tepla a za studena a z plechov s povrchovou úpravou, vrátane žiarovo pozinkovaných plechov, pocínovaných plechov, lakoplastových plechov a z dynamo plechov určených do rôznych priemyselných odvetví.

Okrem ocelových plechov spoločnosť tiež vyrába špirálovo zvarané rúry a ocelové panelové radiátory pod obchodným označením KORAD.

KVALITA VÝROBY

Spoločnosť U. S. Steel Košice zaviedla a používa systém manažérstva kvality v zmysle normy EN ISO 9001 a systém environmentálneho manažérstva podľa EN ISO 14 001, vydaných TUV NORD Slovakia. Spoločnosť je tiež držiteľom viacerých medzinárodných i domácich výrobných certifikátov udelených radiátorom KORAD.

Okrem kvalitných produktov spoločnosť poskytuje svojim zákazníkom aj komplexné technické a poradenské služby v oblasti:

- výskumnu
- technického servisu zákazníkom
- marketingu a obchodu

Tradícia v poskytovaní kvalitných výrobkov a služieb a predovšetkým dôvera partnerov sú hodnoty, ktoré je spoločnosť U. S. Steel Košice pevne odhodlaná chrániť a naďalej rozvíjať.

INOVÁCIE, TRADÍCIA, KVALITA - VÝROBA RADIÁTOROV KORAD V U. S. STEEL KOŠICE, s.r.o.

Výroba ocelových radiátorov má v rámci našej spoločnosti mnohoročnú tradíciu siahajúcu až do roku 1968. Panelové radiátory Korad sa v rámci spoločnosti U. S. Steel Košice vyrábajú v samostatnej výrobnej jednotke Rúry a radiátory vybavené modernými linkami s vysokou mierou automatizácie.

Vstupný materiál pre výrobu radiátorov sú plechy valcované za studena so špecifickým zložením. Aby bola dosahovaná najvyššia kvalita týchto plechov, odborní pracovníci priebežne sledujú a upravujú chemické a mechanické parametre materiálov od vstupných surovín až po finálny produkt.

Zvitky plechov valcovaných za studena znovu odvíjajú, strihajú na požadovaný rozmer, formujú a zvarujú do požadovaného tvaru. Každý výrobok prechádza tlakovou skúškou, ktorá zaručí, že radiátor bude schopný dlhodobo bezchybne plniť svoju funkciu. V nasledujúcej časti linky

radiátory prechádzajú sériou povrchových úprav. Poslednou z úprav je kateforetické nanášanie povrchovej práškovej farby, po ktorej výrobok pokračuje do vypalovacej pece. Po osadení krytov je radiátor pripravený na balenie.

Ochrane radiátorov pri skladovaní a doprave sa venuje mimoriadna pozornosť. Každý radiátor je opatrený kartónovým obalom pričom rohy sú chránené trojuholníkovým plastovým profilom. Na koniec je radiátor zabalený do ochrannej plastickej fólie a uskladnený na drevených paletách, na ktorých sa exportuje zákazníkom.

Výroba neustále reaguje na požiadavky trhov a na svetové vývojové trendy priebežnými inováciami, vďaka ktorým radiátory Korad dlhodobo predstavujú moderný výrobok vysokej kvality, o čom svedčí aj skutočnosť, že tento výrobok sa úspešne predáva v celej Európe a je schopný obstáť v najtvrdšej konkurencii špičkových európskych výrobcov.



OBSAH

ZÁKLADNÉ TECHNICKÉ ÚDAJE	4
POSTUP MONTÁŽE	6
PRIPOJENIE RADIÁTOROV DO VYKUROVACEJ SÚSTAVY	7
PRIETOKOVÉ CHARAKTERISTIKY RADIÁTOROV KOMPAKT	8
PRIETOKOVÉ CHARAKTERISTIKY RADIÁTOROV KORAD VK, VKS	9
ROZMIESTNENIE ZÁVESNÝCH DRŽIAKOV	10
PRÍSLUŠENSTVO - MONTÁŽNE PRVKY A NAPÁJACIE ARMATÚRY	11
TEPELNÉ VÝKONY - VÝŠKA 300 mm	12 - 13
TEPELNÉ VÝKONY - VÝŠKA 400 mm	14 - 15
TEPELNÉ VÝKONY - VÝŠKA 500 mm	16 - 17
TEPELNÉ VÝKONY - VÝŠKA 550 mm	18 - 19
TEPELNÉ VÝKONY - VÝŠKA 600 mm	20 - 21
TEPELNÉ VÝKONY - VÝŠKA 900 mm	22 - 23
TEPELNÉ VÝKONY - RADIÁTORY S HLADKÝM ČELNÝM PANELOM (TYP PLAN) A TYP 20 W (ŠÍRKA = 100 mm)	24
PREPOČÍTACIE FAKTORY "f" PRE INÉ PREVÁDZKOVÉ PODMIENKY	25
PRÍKLADY - VÝPOČET PREDNASTAVENIA VENTILOV; PREPOČET VÝKONU PRE INÉ PREVÁDZKOVÉ PODMIENKY	26
ZNAČENIE RADIÁTOROV	27
NEŠTANDARDNÉ FAREBNÉ ODTIENE POVRCHU RADIÁTOROV	27



POPIS VÝROBKU

Radiátory KORAD sú vykurovacie telesá umožňujúce výmenu tepla medzi teplonosným médiom (vodou) a okolitým prostredím.

Teleso radiátora pozostáva z jedného, dvoch alebo troch panelov. Samotný panel radiátora je zvarovaný z dvoch výliskov z oceleových plechov valcovaných za studena, po obvode šľovým zvarom a vo vertikálnych prelisoch bodovými odporovými zvarmi. Rozstup osí vertikálnych kanálikov je 33,33 mm.

Pre zvýšenie tepelného výkonu sa u niektorých typov radiátorov pridáva jedna, dve alebo tri rozšírené prestupné plochy z ohýbaného oceleového plechu - konvektory. Konvektor je bodovo privarený na vertikálnych kanálikoch telies. Jeho plocha zvyšuje tepelný výkon vykurovacieho telesa o cca 30%.

Radiátor typ Ventil-Kompakt (VK) je dodávaný so špeciálnou garnitúrou pre spodné pripojenie a ventilovou vložkou s prestaviteľnými hodnotami k_v . Radiátory typ VK sú dodávané s pripojením vpravo, vľavo alebo so stredovým pripojením (VKS).

Všetky typy radiátorov môžu byť dodané vo vyhotovení s hladkou čelnou plochou - vyhotovenie PLAN (-P).

TECHNICKÉ PARAMETRE

Technické parametre oceleových panelových radiátorov KORAD spĺňajú požiadavky normy EN 442-1:1997/A1:2004. Radiátory sú certifikované podľa EN 442:1 notifikovanou osobou č. ES1015, Strojirenský zkušební ústav, s. p. Brno, Česká republika a na základe vydaného Vyhlásenia zhody sú označené značkou CE.

Spĺnenie kvalitatívnych požiadaviek podľa EN 442 potvrdzujú aj výkonové skúšky radiátorov vykonané renomovaným akreditovaným laboratóriom HLK Stuttgart a registráciou v DIN CERTCO v Berlíne. Prehlásenie o zhode a certifikáty je možné stiahnuť zo stránky www.usskorad.sk, alebo môžu byť zaslané na požiadanie.

TYPOVÝ SORTIMENT

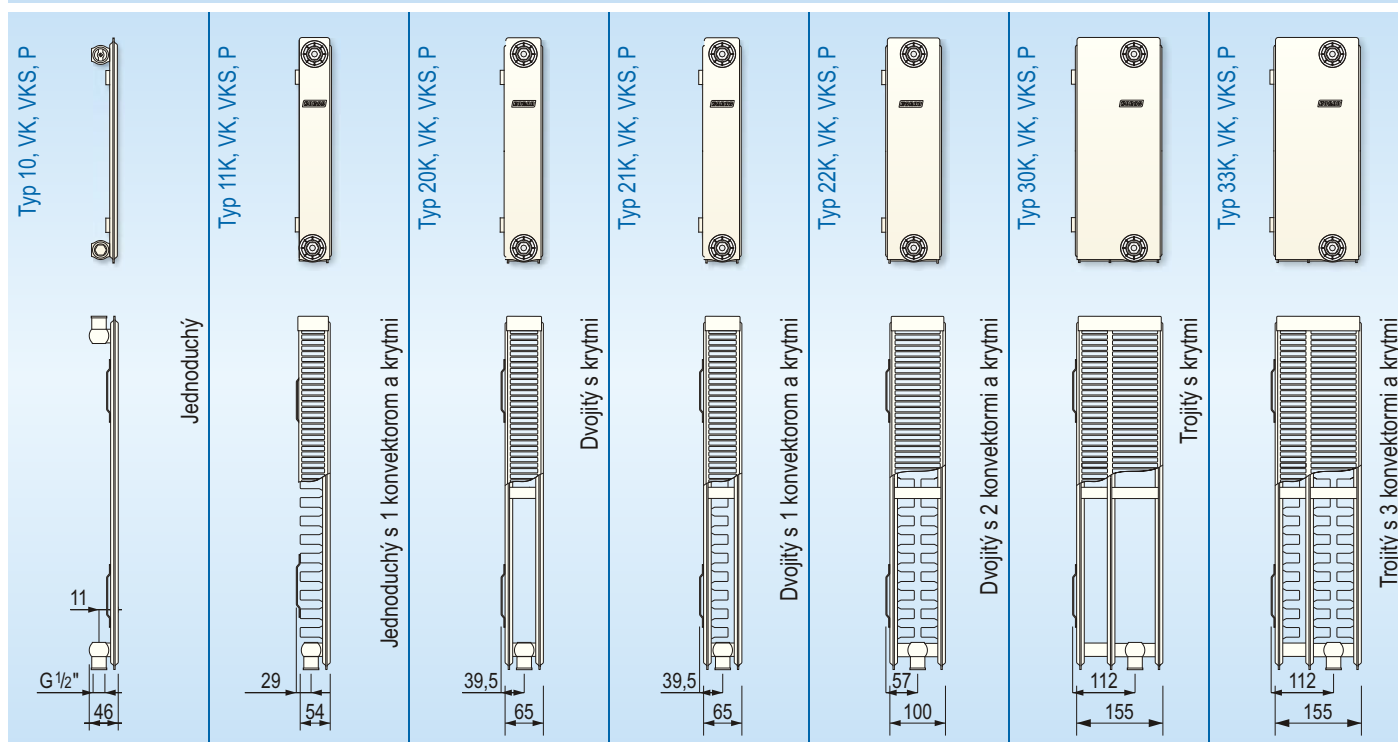

MATERIÁL

Panelový radiátor KORAD a konvektor je vyrobený z oceleového plechu valcovaného za studena vyrábaného spoločnosťou U. S. Steel Košice podľa STN EN 10130+A1.

Použitie plechy z nízkouhlíkovej ocele sú charakterizované zvýšenou pevnosťou a dobrou zvariteľnosťou.

POVRCHOVÁ ÚPRAVA

- odmastenie
- fosfátová vrstva
- základná kataforetická farba
- krycia vrstva - elektrostaticky nanosená prášková farba - odtieň RAL 9010

Poznámka: štandardná farba povrchu radiátorov - RAL 9010; iné farby na základe objednávky - viď str. 27.

TLAK, TEPLOTA

minimálny skúšobný tlak	1,3 MPa
maximálny prevádzkový tlak	1,0 MPa
maximálna teplota teplonosnej látky	110 °C

Na každom radiátore je vykonaná skúška na tesnosť.

POČET PANELOV A KONVEKTOROV

TYP	10	11	20	21	22	30	33
Počet panelov	1	1	2	2	2	3	3
Počet konvektorov	0	1	0	1	2	0	3

VÝŠKOVÝ A DĹŽKOVÝ SORTIMENT KORAD [mm]

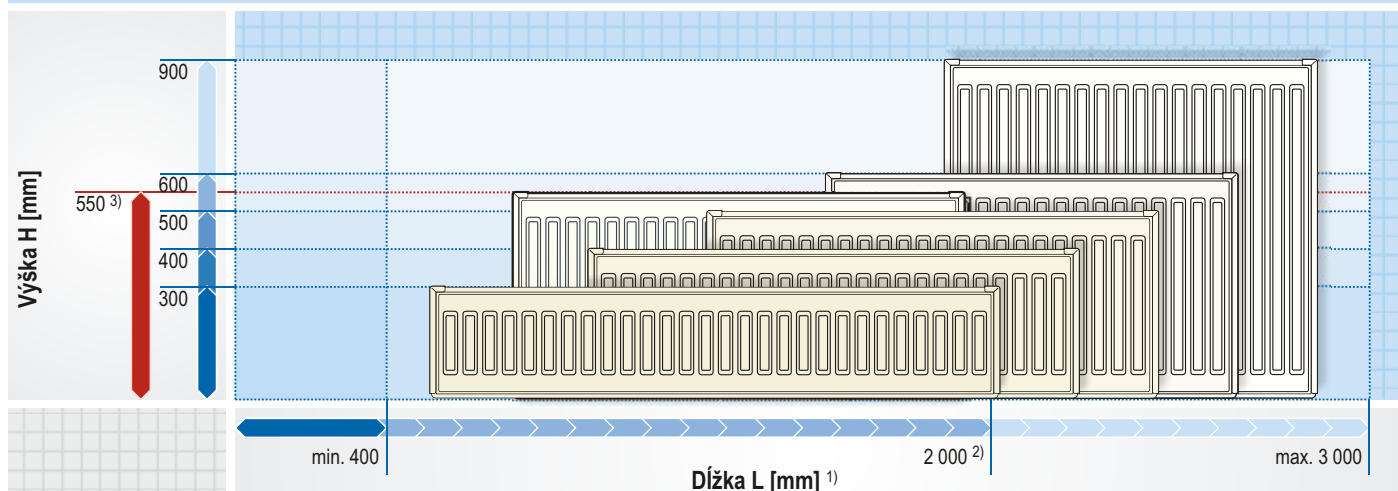

1) Výrobná dĺžka radiátorov je odstupňovaná po 100 mm

2) Radiátory typu 11 a vyhotovenie VKS a PLAN sú vyrábané iba do dĺžky 2 000 mm

3) Radiátory výšky 550 mm sa vyrábajú len vo vyhotovení Kompakt a Kompakt PLAN v zúženom dĺžkovom sortimente - viď strana 18 - 19

NAPOJENIE TELESA DO SÚSTAVY - TYP K

- 4 x vnútorný závit G 1/2"
- pripojovací rozostup = konštrukčná výška H - 54 mm

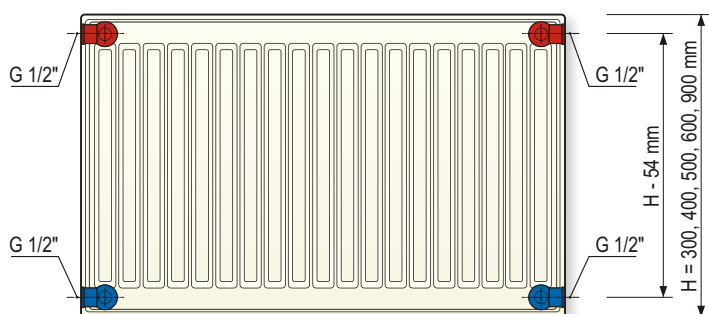

NAPOJENIE TELESA DO SÚSTAVY - TYP VK

- 2 x vnútorný závit pre pripojenie od spodu telesa G 1/2"
- pripojovací rozostup = 50 mm ± 0,5 mm
- termostátový ventil so závitom M 30 x 1,5 mm
- 4 x vnútorný závit pre bočné pripojenie G 1/2"
- pripojovací rozostup = konštrukčná výška H - 54 mm

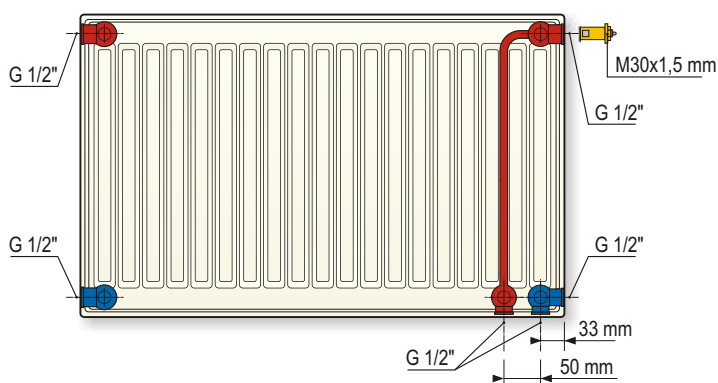

UMIESTNENIE

Panelové radiátory KORAD sú určené do vykurovaných priestorov s nízkou relatívnou vlhkosťou (30 - 60%) a zanedbateľným znečistením, napr. byty, kancelárie, školy, hotely, obchody, múzeá a pod. Je možné ich použiť i v prostredí s vyššou relatívnou vlhkosťou, avšak bez výskytu kondenzácie a znečistenia ovzdušia, ako sú napr. športové zariadenia, sklady, chodby, musí však byť zabezpečené dostatočné a pravidelné vetranie alebo stála prevádzka radiátorov.

Panelové radiátory je najvhodnejšie situovať min. 140 mm pod okennú parapetu do zvislej osi okna vo výške min. 70 mm od podlahy. Vzdialenosť od steny je spravidla určená kotevnými prvkami, ale nemala by byť menej, ako 30 mm. Musí byť umožnené voľné prúdenie vzduchu okolo prestupných plôch radiátora. Maximálny odporúčaný sklon radiátora je 45° (podkrovné priestory). Pri nedodržaní týchto vzdialeností je potrebné rátať s poklesom tepelného výkonu.

Telesá je potrebné umiestniť tak, aby boli mimo dosah vody rozstrekovanej zo sprchy, umývadla, drezu a pod. Do priestorov so zvýšenými hygienickými požiadavkami (zdravotnícke zariadenia) odporúčame použiť radiátory bez rozšírenej prestupnej plochy (konvektor).

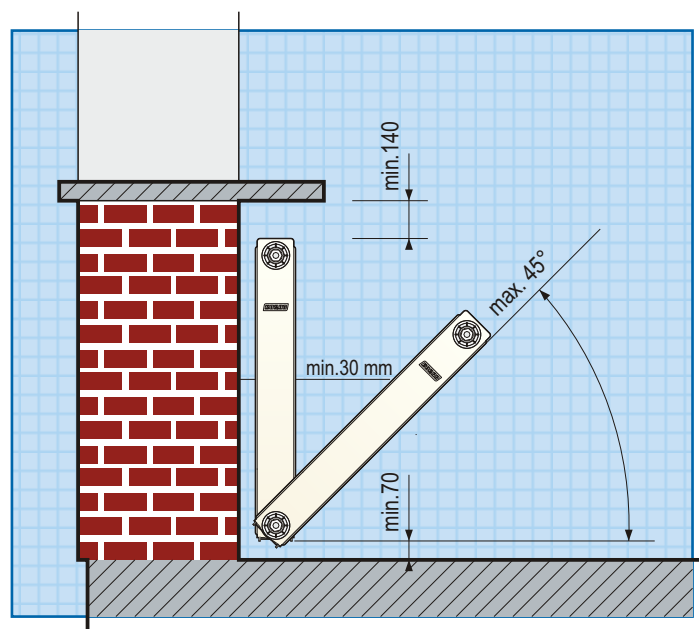

MONTÁŽ RADIÁTORA KORAD KOMPAKT POMOCOU DRŽIAKU KORAD

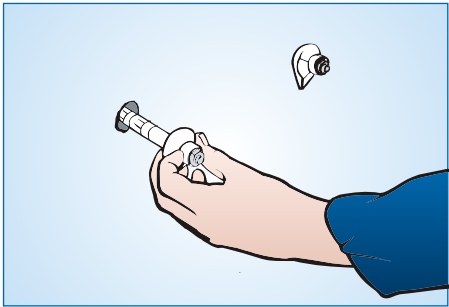

Navrtať otvory do steny a osadiť kotevné držiaky Korad (držiak Korad je zobrazený na str. 11)

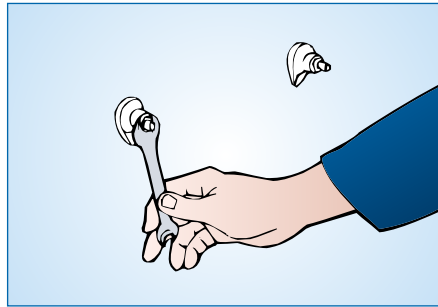

Držiaky opatrne zafixovať utiahnutím matice.

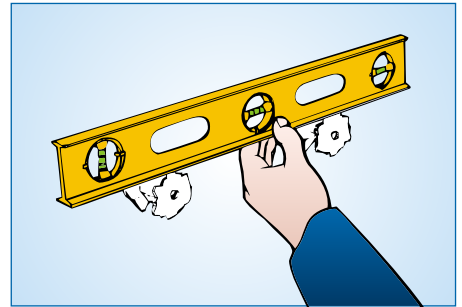

Skontrolovať výškovú nivelizáciu nastavenia držiakov.

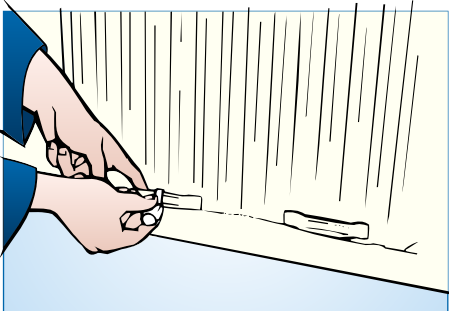

Odstrániť polystyrénové ochrany závesných držiakov, namontovať opierky na spodné závesné držiaky radiátora.

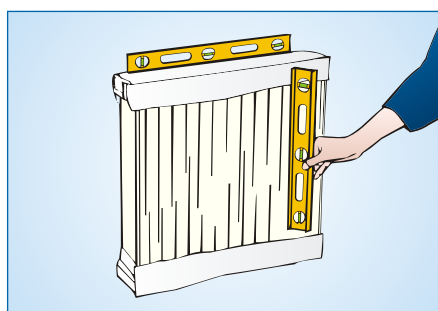

Zavesiť radiátor na kotevné držiaky a skontrolovať vodorovnú a zvislú polohu.

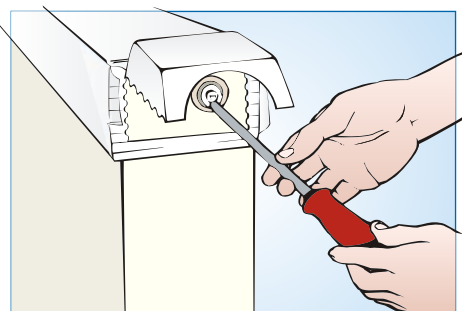

Odstrániť plastové prepravné zátky.

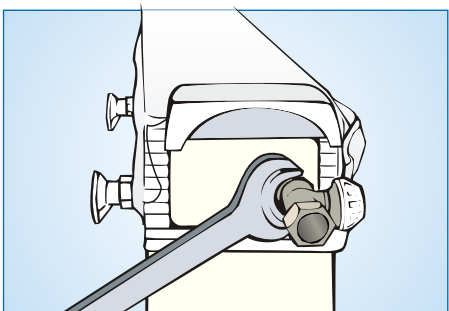

Namontovať odvzdušňovaciu zátku, záslepku, ventil a napojiť na vykurovací okruh.

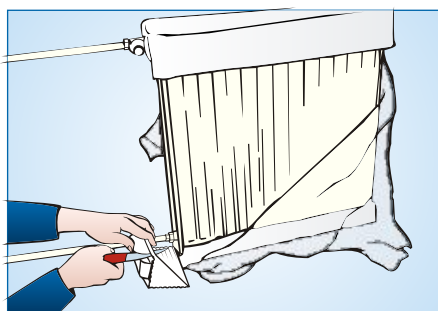

Po ukončení stavebných prác odstrániť fólie, kartóny a plastové rohy.

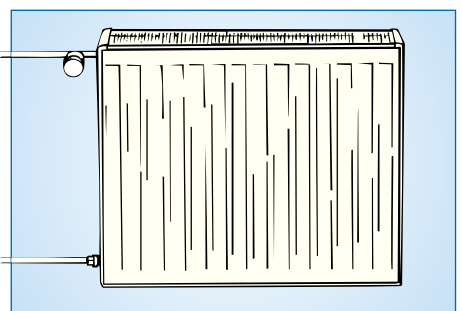

Správne nainštalovaný radiátor.

POKYNY PRE MONTÁŽ

- montáž radiátorov doporučujeme vykonávať v zabalenom stave, čím sa zabezpečí maximálna ochrana radiátorov až do ukončenia všetkých stavebných prác. Montážne prvky umožňujú vykonať takúto montáž s minimálnym narušením obalu v miestach závesných konzol, opierok a napojení na vykurovací okruh.
- pred montážou narežte ochrannú fóliu v mieste závesných konzol a plastových ochranných rohov. Ochranné rohy sú navrhnuté tak, že je ich možné v mieste pripojenia radiátora odklopiť.
- odstráňte plastové zaslepovacie zátky. V žiadnom prípade nepoužívajte plastové zátky pri prevádzkovaní radiátora!
- namontujte potrebné ventily, záslepky a odvzdušňovaciu zátku.
- radiátory je potrebné inštalovať so sklonom 10 až 20 mm na 1m dĺžky tak, aby sa odvzdušňovacia zátku nachádzala na najvyššom mieste.
- návod na montáž a použitie je priložený v každom vyhrievacom telese pod ochrannou PE fóliou

ÚPOZORNENIE

Pred spustením systému prekontrolovať dotiahnutie zátok na garnitúrach!

BALENIE

Každý radiátor je balený do PE fólie. Hrany radiátora sú chránené kartónom formovaným do tvaru U, rohy sú chránené plastovým uholníkom. Počas skladovania a prepravy sú radiátory uložené na nevratných drevených paletách v zmysle paletizačného plánu.

ČISTENIE A ÚDRŽBA

Na čistenie radiátora je možné použiť čistiace prostriedky určené na čistenie lakovaných povrchov. Nepoužívajte abrazívne čistiace prostriedky ani prostriedky obsahujúce chlór a kyseliny.

ZÁRUKA

Pri použití výrobku na určený účel a pri dodržaní záručných podmienok, ktoré sú priložené v obale sa na radiátory vzťahuje záruka 10 rokov.

Poznámka: technické zmeny sú vyhradené.

PRIPOJENIE RADIÁTOROV DO VYKUROVACEJ SÚSTAVY

Podľa spôsobu pripojenia na vykurovaciu sústavu sa radiátory Korad členia po konštrukčnej stránke na typ Korad Kompakt (K) a typ Korad Ventil Kompakt (VK).

Radiátory Korad Kompakt sú určené pre bočné pripojenia do vykurovacej sústavy so samospádovým alebo núteným obehom.

Radiátory Ventil Kompakt sú určené predovšetkým pre spodné pripojenie do sústav s núteným obehom, ale umožňujú tiež i jednostranné bočné pripojenie podobne, ako typ Korad Kompakt.

VENTILOVÁ VLOŽKA

Radiátor KORAD Ventil-Kompakt je dodávaný s ventilovou vložkou Heimeier - typ 4360, ktorá je zamontovaná v garnitúre radiátora a slúži na reguláciu a hydraulické nastavenie.

Ventilová vložka je opatrená plastovou krytkou, ktorá ju chráni pred poškodením pri transporte a inštalácií vykurovacieho telesa a zároveň umožňuje ručnú reguláciu.

Priamo na radiátor KORAD Ventil-Kompakt je možné nasadiť termostatovú hlavicu, ktorá umožňuje reguláciu teploty v miestnosti. Pripojovací závit pre termostatovú hlavicu je M 30 x 1,5 mm.

PRIPOJENIE RADIÁTORA KORAD KOMPAKT

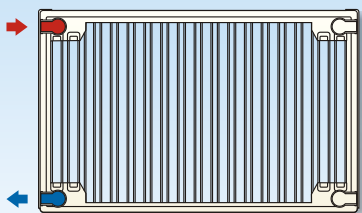

Pripojenie jednostranné
 $\varphi = 1$

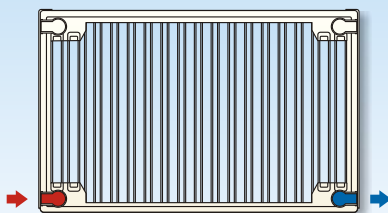

Pripojenie obojstranné spodné
 $\varphi = 0,9$

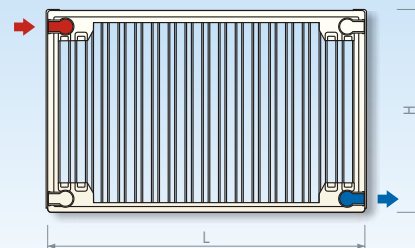

Pripojenie bočné križové
 $\varphi = 1$ doporučené pri: $L \geq 3 \times H$

PRIPOJENIE RADIÁTORA KORAD VKL, VKS, VKP

JEDNORÚRKOVÝ SYSTÉM

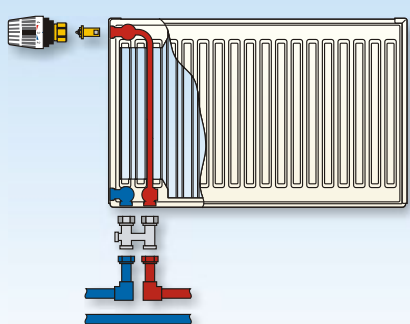

Pripojenie vľavo

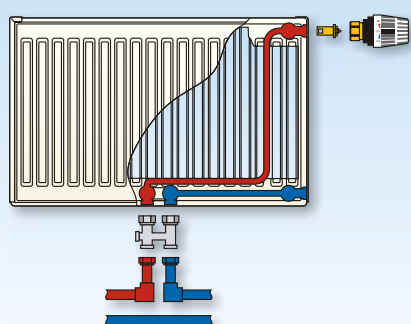

Pripojenie v strede

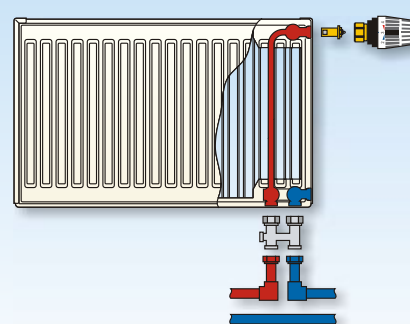

Pripojenie vpravo

PRIPOJENIE RADIÁTORA KORAD VKL, VKS, VKP

DVOJRÚRKOVÝ SYSTÉM

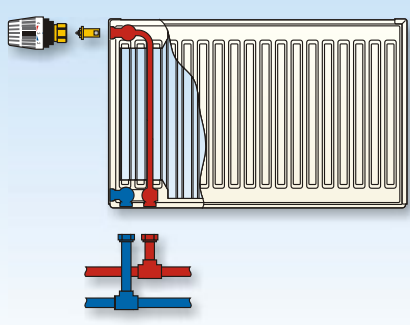

Pripojenie vľavo

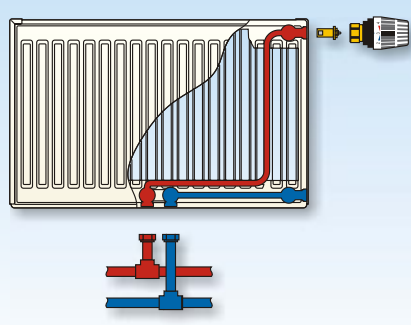

Pripojenie v strede

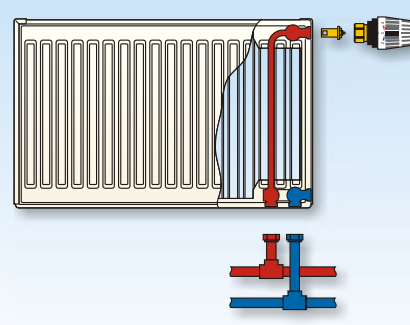

Pripojenie vpravo

ODPORÚČANÉ VENTILOVÉ HLAVICE

Výrobca	Typ termostatovej hlavice
Heimeier	Všetky typy
Comap	IF 1
Danfoss	RAWK
Drayton	TRV 4
Gampper	340012.100
Herz	Porsche design „H“, Mini „H“, Termostat „H“

Výrobca	Typ termostatovej hlavice
Honeywell	Brauckmann T 100 - 361
Oventrop	Uni LH
MNG	thera 2 / thera 3
Rosswainer	Star Tec
Ivar	typ 3000, typ 5000
Siemens	RTN 51

ROVNICA PRE VÝPOČET TLAKOVÝCH STRÁT

pre teplotnosnú látku vodu

$$\Delta p = \frac{M_w^2}{A_T^2 \cdot \rho_w \cdot 1,296} \cdot 10^{-10} = \left[\frac{\dot{V}}{A_T} \right]^2 \cdot \rho_w \cdot 10^{-3} = \xi_T \cdot \frac{w^2}{2} \cdot \rho_w \cdot 10^{-3} \text{ [kPa]}$$

PRIETOKOVÉ CHARAKTERISTIKY RADIÁTOROV KORAD KOMPAKT

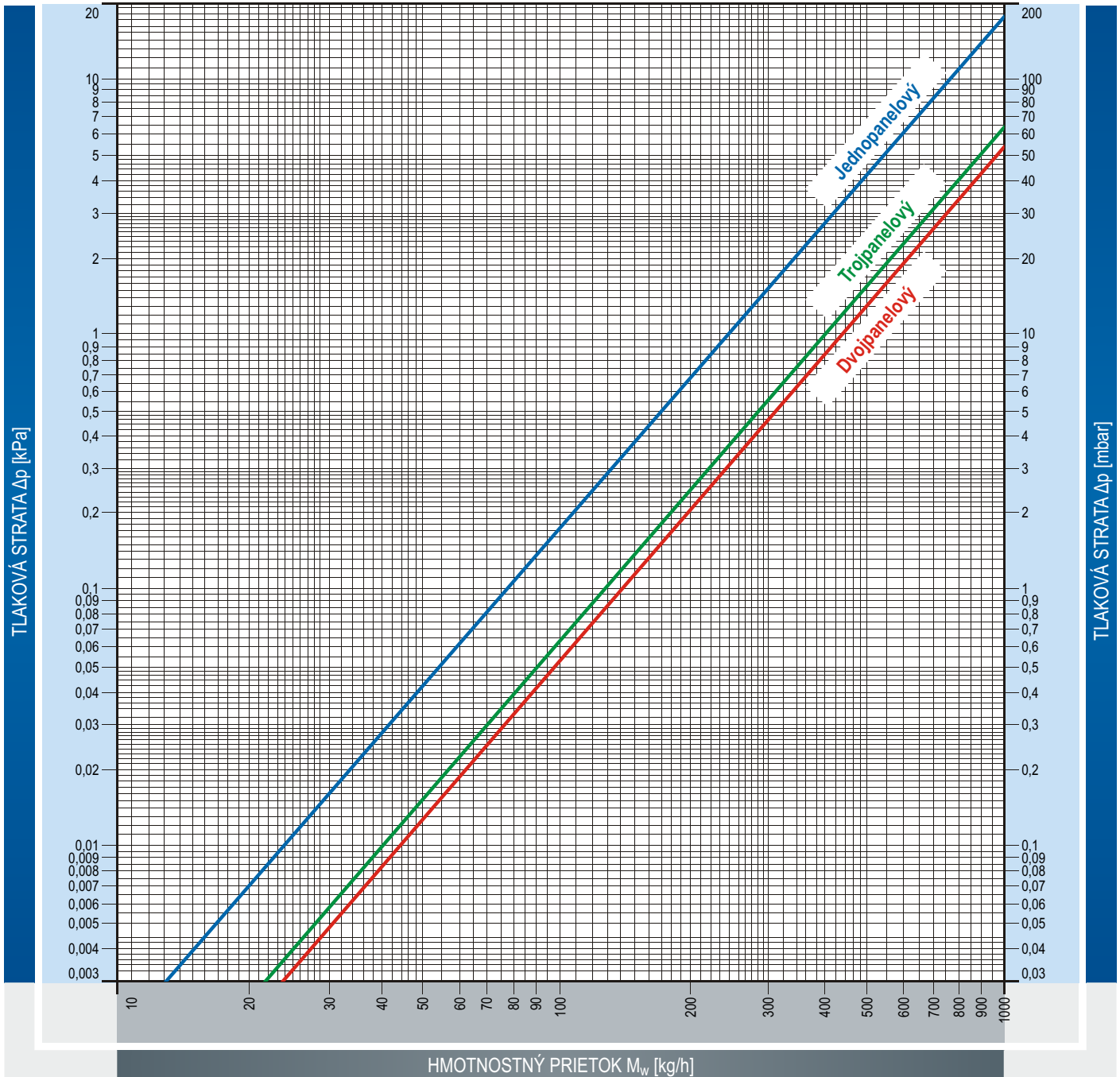

PRIETOKOVÉ PARAMETRE PRE TYP KOMPAKT

Typ	Veľičina	Pre rozmer prípojky G 1/2"
Jednopanelový 10, 11	A_T [m ²]	$6,64 \cdot 10^{-5}$
	ξ_T [-]	18,4
Dvojpanelový 20, 21, 22	A_T [m ²]	$1,2 \cdot 10^{-4}$
	ξ_T [-]	5,62
Trojpanelový 30, 33	A_T [m ²]	$1,10 \cdot 10^{-4}$
	ξ_T [-]	6,7

POUŽITÉ SYMBOLY

M_w [kg/h]	hmotnostný prietok
Δp [kPa]	tlaková strata
\dot{V} [m ³ ·s ⁻¹]	objemový prietok
A_T [m ²]	prietokový súčiniteľ
ρ_w [kg·m ⁻³]	hustota teplotnosného média
ξ_T [-]	súčiniteľ odporu
w [m·s ⁻¹]	rýchlosť vykurovacieho média vzťahovaného na vnútorný priemer pripájaných rúrok

ROVNICA PRE VÝPOČET HMOTNOSTNÉHO PRIETOKU

pre teplotnosnú látku vodu

$$M_w = \frac{\Phi}{C \cdot \Delta t} \text{ [kg} \cdot \text{h}^{-1}]$$

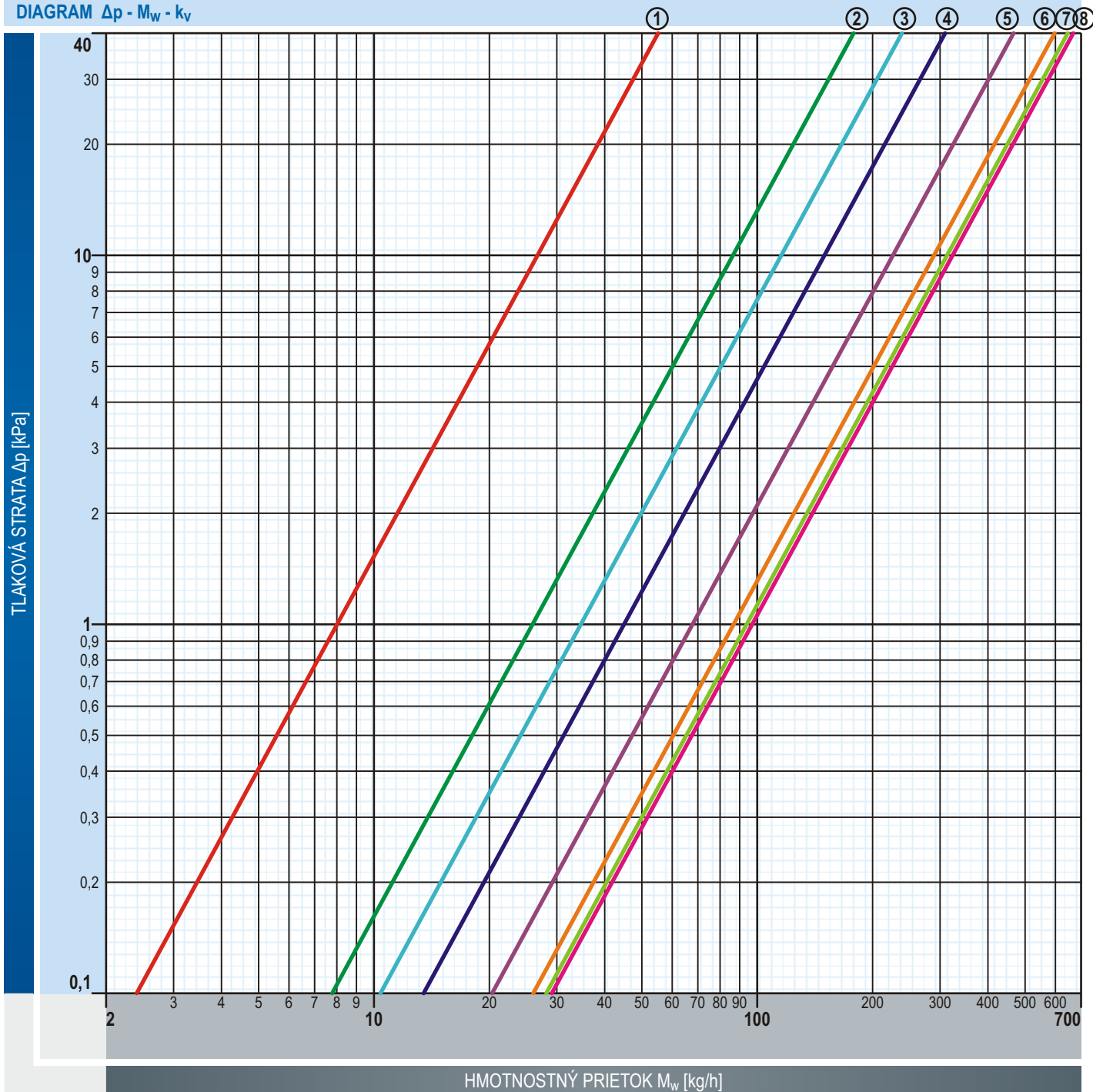
DIAGRAM $\Delta p - M_w - k_v$ 

NASTAVENIE PRIETOKU VENTILOVEJ VLOŽKY

prednastavenie ventilu							
①	②	③	④	⑤	⑥	⑦	⑧
0,089	0,288	0,385	0,499	0,753	0,964	1,044	1,084
hodnota k_v [m ³ /h]							
max. teplota teplotnosnej látky						110 °C	
max. prevádzkový tlak						1 MPa	

POUŽITÉ SYMBOLY

M_w	[kg · h ⁻¹]	hmotnostný prietok
Φ	[W]	tepelný výkon
Δt	[K]	pokles teploty vody
Δp	[kPa]	tlaková strata
C	[m ² · s ⁻² · K ⁻¹]	špecifické teplo vody = 4 186
k_v	[m ³ · h ⁻³]	hustota teplotnosného média

Príklad výpočtu nastavenia ventilu je na strane 26.

Radiátory Korad VK sú dodávané s ventilom Heimeier typ 4360, ktorý umožňuje nastavenie medzipolohy.

TYPY

10, 10VK, 10VKS
 20K, 20VK, 20VKS
 21K, 21VK, 21VKS
 22K, 22VK, 22VKS
 30K, 30VK, 30VKS
 33K, 33VK, 33VKS
 a vyhotovenie PLAN

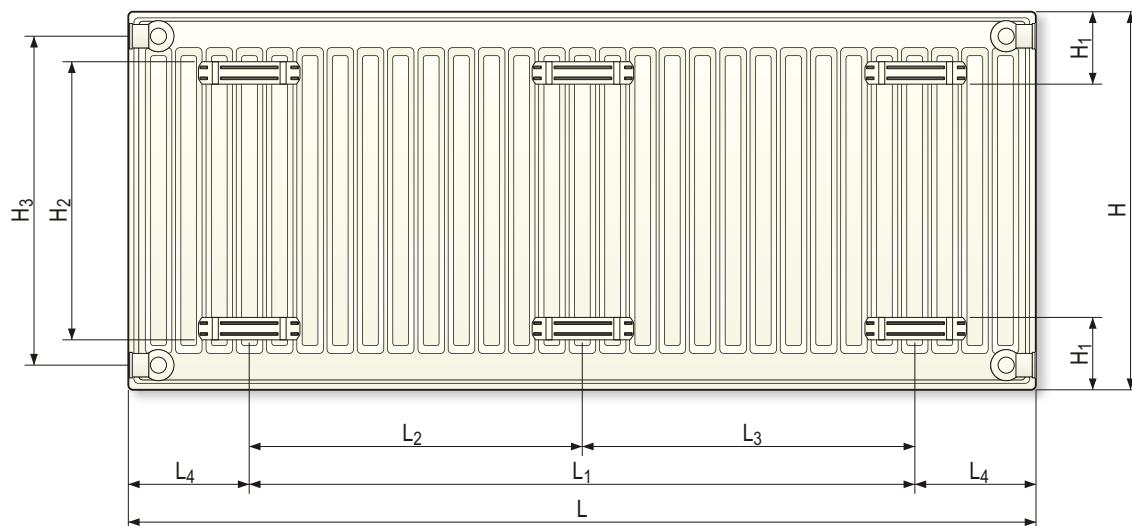
ROZMIESTNENIE ZÁVESNÝCH DRŽIAKOV
zvislé rozmery
vodorovné rozmery

Dĺžka L* [mm]	Počet držiačkov	L ₁ [mm]	L ₂ [mm]	L ₃ [mm]	L ₄ [mm]
400	4	L - 200	-	-	100
500, 600, 700, 800, 900, 1 000, 1 100, 1 200, 1 300, 1 400, 1 500, 1 600	4	L - 266	-	-	133
1 700, 1 900, 2 100, 2 300, 2 500, 2 700, 2 900	6	L - 266	L ₁ /2 + 16,5	L ₁ /2 - 16,5	133
1 800, 2 000, 2 200, 2 400, 2 600, 2 800, 3 000	6	L - 266	L ₁ /2	L ₁ /2	133

Výška H [mm]	H ₁ [mm]	H ₂ [mm]	H ₃ [mm]
300	90	H - 130	H - 54
400			
500			
550			
600			
900			

* Radiátory s hladkou čelnou plochou (PLAN) sa vyrábajú len do dĺžky 2 000 mm.

TYP

11K, 11VK, 11VKS
 a vyhotovenie PLAN

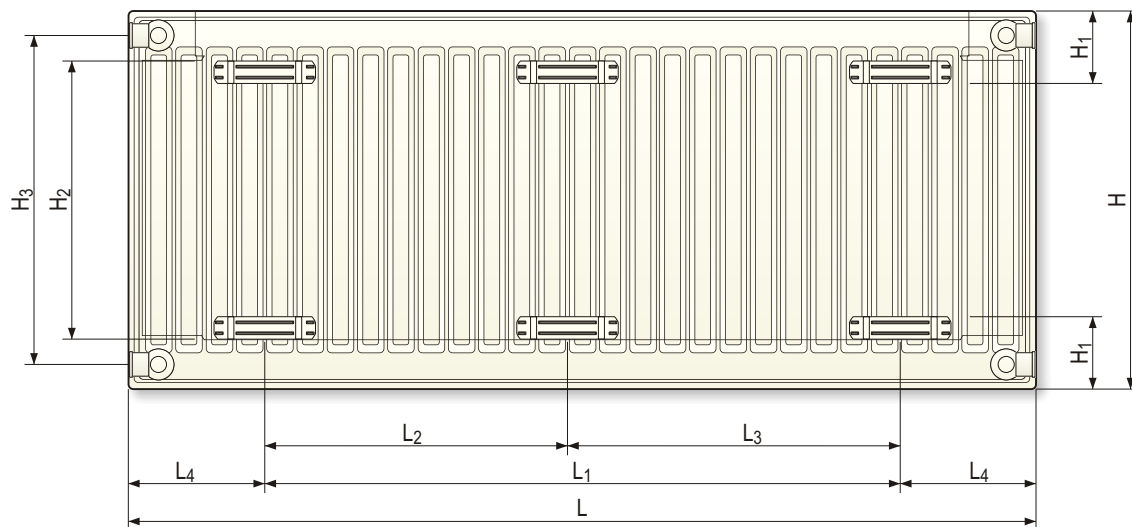
ROZMIESTNENIE ZÁVESNÝCH DRŽIAKOV
zvislé rozmery
vodorovné rozmery

Dĺžka L [mm]	Počet držiačkov	L ₁ [mm]	L ₂ [mm]	L ₃ [mm]	L ₄ [mm]
400	4	L - 234	-	-	117
500, 600, 700, 800, 900, 1 000, 1 100, 1 200, 1 300, 1 400, 1 500, 1 600	4	L - 300	-	-	150
1 700, 1 900	6	L - 300	L ₁ /2 - 16,5	L ₁ /2 + 16,5	150
1 800, 2 000	6	L - 300	L ₁ /2	L ₁ /2	150

Výška H [mm]	H ₁ [mm]	H ₂ [mm]	H ₃ [mm]
300	90	H - 130	H - 54
400			
500			
550			
600			
900			

MONTÁŽNE PRVKY

K montáži vykurovacích telies ponúkame niekoľko typov upevňovacích konzol a opierok používaných v závislosti od stavebného materiálu steny. Držiak KORAD, ktorý je najpoužívanejším typom montážnej konzoly je vhodný pre plné stavebné materiály, nie však pre steny z dierovaných tehál! Pre sadrokartónové alebo presklené steny odporúčame stojanové konzoly.

Príslušenstvo k panelovým radiátorom, t.j. odvzdušňovacie zátky a záslepky, ako aj upevňovacie dielce (konzoly a opierka) dodáva výrobca panelových radiátorov na základe osobitnej objednávky.

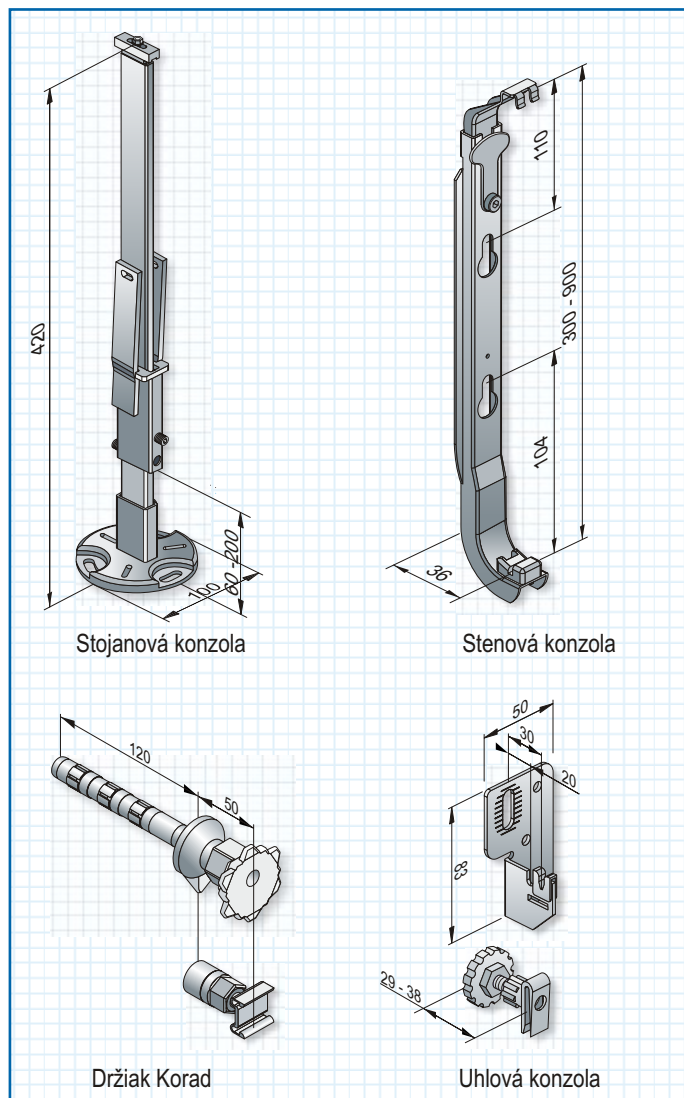
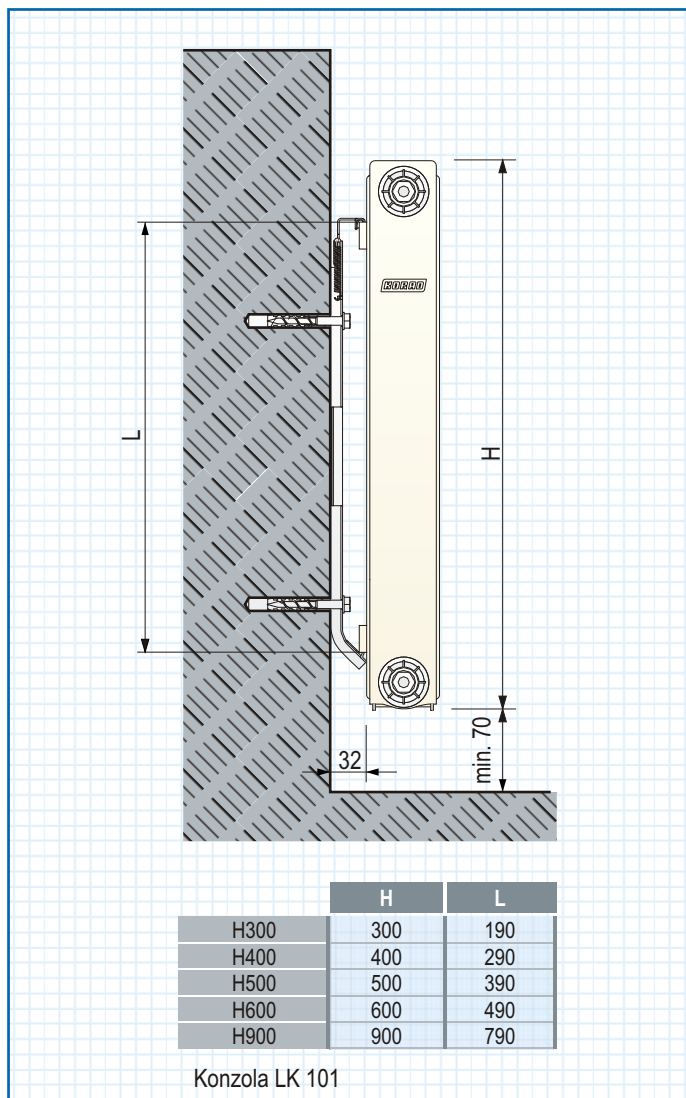

NAPÁJACIE ARMATÚRY

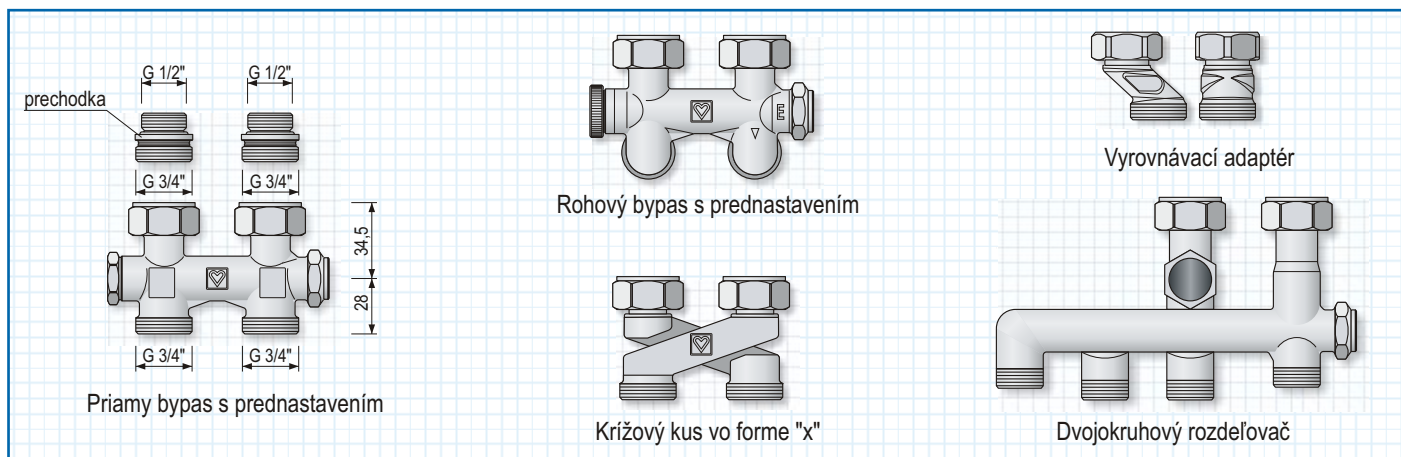

Upozornenie: zobrazené kotevné prvky a armatúry nie sú súčasťou dodávky radiátorov !

TYPY RADIÁTOROV

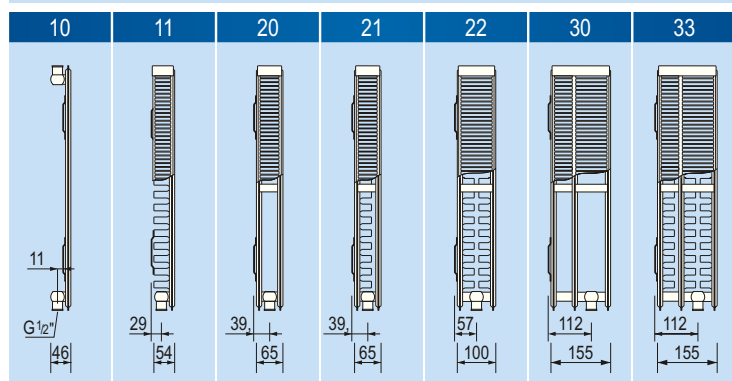

ZÁKLADNÉ TECHNICKÉ ÚDAJE

	Typ radiátora						
	10	11	20	21	22	30	33
M_T^K [kg·m ⁻¹]	6,75	10,60	14,06	14,97	17,13	21,60	25,31
M_T^{VK} [kg·m ⁻¹]	6,96	10,81	14,25	15,16	17,33	21,79	25,50
V_T [dm ³ ·m ⁻¹]	1,81	1,81	3,50	3,50	3,50	5,20	5,20
n [-]	1,3187	1,2912	1,2630	1,3239	1,3087	1,2831	1,3005

H - výška radiátora
 M_T^K - hmotnosť telesa radiátora Kompakt
 M_T^{VK} - hmotnosť telesa radiátora Ventil Kompakt
 V_T - vodný objem telesa
 n - exponent charakteristiky panelových radiátorov

TYP 10 K, VK, VKS

t_1 / t_2 [°C]	90 / 70			75 / 65			70 / 55			55 / 45		
	15	20	22	15	20	22	15	20	22	15	20	22
400	193	174	166	155	137	130	128	110	102	85	70	63
500	242	217	208	194	171	162	160	138	128	107	87	79
600	290	261	250	233	205	194	192	166	154	128	105	95
700	338	304	291	271	239	227	224	193	179	150	122	110
800	387	348	333	310	274	259	256	221	205	171	139	126
900	435	391	374	349	308	292	288	248	231	192	157	142
1000	483	435	416	388	342	324	320	276	256	214	174	158
1100	532	478	458	427	376	356	352	304	282	235	192	173
1200	580	522	499	465	410	389	384	331	307	256	209	189
1300	628	565	541	504	445	421	416	359	333	278	227	205
1400	677	609	582	543	479	454	447	386	359	299	244	221
1500	725	652	624	582	513	486	479	414	384	321	262	236
1600	773	696	665	620	547	519	511	442	410	342	279	252
1700	822	739	707	659	581	551	543	469	436	363	296	268
1800	870	783	749	698	616	583	575	497	461	385	314	284
1900	918	826	790	737	650	616	607	524	487	406	331	300
2000	967	870	832	776	684	648	639	552	512	427	349	315
2100	1015	913	873	814	718	681	671	580	538	449	366	331
2200	1063	957	915	853	752	713	703	607	564	470	384	347
2300	1112	1000	957	892	787	745	735	635	589	491	401	363
2400	1160	1044	998	931	821	778	767	662	615	513	418	378
2500	1208	1087	1040	970	855	810	799	690	641	534	436	394
2600	1257	1131	1081	1008	889	843	831	718	666	556	453	410
2700	1305	1174	1123	1047	923	875	863	745	692	577	471	426
2800	1353	1218	1165	1086	958	907	895	773	717	598	488	441
2900	1402	1261	1206	1125	992	940	927	800	743	620	506	457
3000	1450	1305	1248	1163	1026	972	959	828	769	641	523	473

TYP 11 K, VK, VKS

t_1 / t_2 [°C]	90 / 70			75 / 65			70 / 55			55 / 45		
	15	20	22	15	20	22	15	20	22	15	20	22
400	306	276	264	247	218	207	204	177	164	138	113	102
500	382	345	330	308	273	259	255	221	205	172	141	128
600	459	414	396	370	327	310	306	265	246	206	169	153
700	535	483	462	431	382	362	357	309	288	241	197	179
800	612	552	528	493	436	414	408	353	329	275	225	204
900	688	621	594	555	491	465	459	398	370	309	254	230
1000	765	690	660	616	545	517	510	442	411	344	282	255
1100	841	759	726	678	600	569	561	486	452	378	310	281
1200	918	828	792	740	654	620	612	530	493	413	338	306
1300	994	897	858	801	709	672	663	574	534	447	366	332
1400	1071	966	924	863	763	724	714	619	575	481	395	357
1500	1147	1034	990	925	818	776	765	663	616	516	423	383
1600	1224	1103	1056	986	872	827	816	707	657	550	451	409
1700	1300	1172	1122	1048	927	879	867	751	698	585	479	434
1800	1377	1241	1188	1109	981	931	918	795	739	619	507	460
1900	1453	1310	1254	1171	1036	982	969	839	780	653	535	485
2000	1530	1379	1320	1233	1090	1034	1020	884	822	688	564	511
2100												
2200												
2300												
2400												
2500												
2600												
2700												
2800												
2900												
3000												

TYP 20 K, VK, VKS

t_1 / t_2 [°C]	90 / 70			75 / 65			70 / 55			55 / 45		
	15	20	22	15	20	22	15	20	22	15	20	22
400	311	281	270	252	224	212	210	182	170	143	117	107
500	389	352	337	315	280	265	262	228	212	178	147	133
600	467	422	405	378	335	319	314	273	254	214	176	160
700	545	493	472	441	391	372	367	319	297	249	205	186
800	623	563	539	504	447	425	419	364	339	285	235	213
900	701	633	607	567	503	478	472	410	382	321	264	240
1000	779	704	674	631	559	531	524	455	424	356	293	266
1100	856	774	742	694	615	584	576	501	466	392	323	293
1200	934	844	809	757	671	637	629	546	509	428	352	320
1300	1012	915	877	820	727	690	681	592	551	463	381	346
1400	1090	985	944	883	783	743	734	637	594	499	411	373
1500	1168	1056	1011	946	839	796	786	683	636	534	440	399
1600	1246	1126	1079	1009	894	849	838	728	678	570	469	426
1700	1324	1196	1146	1072	950	903	891	774	721	606	499	453
1800	1402	1267	1214	1135	1006	956	943	819	763	641	528	479
1900	1479	1337	1281	1198	1062	1009	995	865	805	677	557	506
2000	1557	1407	1349	1261	1118	1062	1048	911	848	713	586	533
2100	1635	1478	1416	1324	1174	1115	1100	956	890	748	616	559
2200	1713	1548	1483	1387	1230	1168	1153	1002	933	784	645	586
2300	1791	1619	1551	1450	1286	1221	1205	1047	975	819	674	612
2400	1869	1689	1618	1513	1342	1274	1257	1093	1017	855	704	639
2500	1947	1759	1686	1576	1398	1327	1310	1138	1060	891	733	666
2600	2024	1830	1753	1639	1453	1380	1362	1184	1102	926	762	692
2700	2102	1900	1820	1702	1509	1433	1415	1229	1145	962	792	719
2800	2180	1970	1888	1765	1565	1487	1467	1275	1187	998	821	746
2900	2258	2041	1955	1828	1621	1540	1519	1320	1229	1033	850	772
3000	2336	2111	2023	1892	1677	1593	1572	1366	1272	1069	880	799

TYP 21 K, VK, VKS

t_1 / t_2 [°C]	90 / 70			75 / 65			70 / 55			55 / 45			
	t_r [°C]	15	20	22	15	20	22	15	20	22	15	20	22
Dĺžka [mm]	400	426	383	366	341	301	285	281	243	225	188	153	138
	500	532	479	458	427	376	356	351	303	281	234	191	173
	600	639	574	549	512	451	427	422	364	338	281	229	207
	700	745	670	641	597	526	499	492	424	394	328	268	242
	800	851	766	732	683	602	570	562	485	450	375	306	276
	900	958	862	824	768	677	641	632	546	506	422	344	311
	1000	1064	957	915	853	752	712	703	606	563	469	382	346
	1100	1171	1053	1007	938	827	784	773	667	619	516	421	380
	1200	1277	1149	1098	1024	902	855	843	728	675	563	459	415
	1300	1384	1244	1190	1109	978	926	913	788	732	610	497	449
	1400	1490	1340	1281	1194	1053	997	984	849	788	657	535	484
	1500	1596	1436	1373	1280	1128	1069	1054	910	844	703	574	518
	1600	1703	1532	1464	1365	1203	1140	1124	970	900	750	612	553
	1700	1809	1627	1556	1450	1278	1211	1194	1031	957	797	650	588
	1800	1916	1723	1648	1536	1354	1282	1265	1092	1013	844	688	622
	1900	2022	1819	1739	1621	1429	1354	1335	1152	1069	891	727	657
	2000	2129	1915	1831	1706	1504	1425	1405	1213	1125	938	765	691
	2100	2235	2010	1922	1792	1579	1496	1476	1273	1182	985	803	726
	2200	2341	2106	2014	1877	1654	1567	1546	1334	1238	1032	841	760
	2300	2448	2202	2105	1962	1730	1639	1616	1395	1294	1079	880	795
2400	2554	2298	2197	2048	1805	1710	1686	1455	1351	1126	918	829	
2500	2661	2393	2288	2133	1880	1781	1757	1516	1407	1172	956	864	
2600	2767	2489	2380	2218	1955	1852	1827	1577	1463	1219	994	899	
2700	2874	2585	2471	2303	2030	1924	1897	1637	1519	1266	1032	933	
2800	2980	2680	2563	2389	2106	1995	1967	1698	1576	1313	1071	968	
2900	3086	2776	2654	2474	2181	2066	2038	1759	1632	1360	1109	1002	
3000	3193	2872	2746	2559	2256	2137	2108	1819	1688	1407	1147	1037	

TYP 22 K, VK, VKS

t_1 / t_2 [°C]	90 / 70			75 / 65			70 / 55			55 / 45			
	t_r [°C]	15	20	22	15	20	22	15	20	22	15	20	22
Dĺžka [mm]	400	554	499	477	445	393	373	368	318	295	247	202	182
	500	693	624	597	557	492	466	460	397	369	308	252	228
	600	831	749	716	668	590	559	552	477	443	370	302	273
	700	970	874	836	780	688	652	643	556	517	431	353	319
	800	1109	998	955	891	786	745	735	636	590	493	403	365
	900	1247	1123	1074	1002	885	839	827	715	664	555	453	410
	1000	1386	1248	1194	1114	983	932	919	795	738	616	504	456
	1100	1524	1373	1313	1225	1081	1025	1011	874	812	678	554	501
	1200	1663	1497	1432	1336	1180	1118	1103	954	886	740	605	547
	1300	1801	1622	1552	1448	1278	1211	1195	1033	959	801	655	593
	1400	1940	1747	1671	1559	1376	1305	1287	1113	1033	863	705	638
	1500	2079	1872	1791	1670	1475	1398	1379	1192	1107	925	756	684
	1600	2217	1997	1910	1782	1573	1491	1471	1271	1181	986	806	729
	1700	2356	2121	2029	1893	1671	1584	1563	1351	1255	1048	856	775
	1800	2494	2246	2149	2004	1769	1677	1655	1430	1329	1109	907	820
	1900	2633	2371	2268	2116	1868	1771	1746	1510	1402	1171	957	866
	2000	2771	2496	2387	2227	1966	1864	1838	1589	1476	1233	1008	912
	2100	2910	2621	2507	2339	2064	1957	1930	1669	1550	1294	1058	957
	2200	3049	2745	2626	2450	2163	2050	2022	1748	1624	1356	1108	1003
	2300	3187	2870	2746	2561	2261	2143	2114	1828	1698	1418	1159	1048
2400	3326	2995	2865	2673	2359	2236	2206	1907	1771	1479	1209	1094	
2500	3464	3120	2984	2784	2458	2330	2298	1987	1845	1541	1259	1140	
2600	3603	3245	3104	2895	2556	2423	2390	2066	1919	1603	1310	1185	
2700	3741	3369	3223	3007	2654	2516	2482	2146	1993	1664	1360	1231	
2800	3880	3494	3342	3118	2752	2609	2574	2225	2067	1726	1411	1276	
2900	4019	3619	3462	3229	2851	2702	2666	2305	2140	1787	1461	1322	
3000	4157	3744	3581	3341	2949	2796	2758	2384	2214	1849	1511	1367	

TYP 30 K, VK, VKS

t_1 / t_2 [°C]	90 / 70			75 / 65			70 / 55			55 / 45			
	t_r [°C]	15	20	22	15	20	22	15	20	22	15	20	22
Dĺžka [mm]	400	464	418	401	374	331	314	310	269	250	210	172	156
	500	580	523	501	468	414	393	388	336	313	262	215	195
	600	696	628	601	561	497	471	465	403	375	314	258	234
	700	812	732	701	655	580	550	543	471	438	367	301	273
	800	928	837	801	749	662	629	620	538	500	419	344	312
	900	1043	942	902	842	745	707	698	605	563	472	387	351
	1000	1159	1046	1002	936	828	786	775	672	625	524	430	390
	1100	1275	1151	1102	1029	911	864	853	739	688	576	473	429
	1200	1391	1255	1202	1123	994	943	930	807	750	629	516	468
	1300	1507	1360	1302	1216	1076	1021	1008	874	813	681	559	507
	1400	1623	1465	1402	1310	1159	1100	1085	941	875	734	602	546
	1500	1739	1569	1503	1404	1242	1179	1163	1008	938	786	645	585
	1600	1855	1674	1603	1497	1325	1257	1240	1075	1000	838	688	624
	1700	1971	1779	1703	1591	1408	1336	1318	1143	1063	891	731	663
	1800	2087	1883	1803	1684	1490	1414	1395	1210	1125	943	774	702
	1900	2203	1988	1903	1778	1573	1493	1473	1277	1188	995	817	741
	2000	2319	2092	2003	1871	1656	1571	1551	1344	1250	1048	860	780
	2100	2435	2197	2104	1965	1739	1650	1628	1412	1313	1100	903	818
	2200	2551	2302	2204	2059	1822	1729	1706	1479	1375	1153	946	857
	2300	2667	2406	2304	2152	1904	1807	1783	1546	1438	1205	989	896
2400	2783	2511	2404	2246	1987	1886	1861	1613	1500	1257	1032	935	
2500	2898	2616	2504	2339	2070	1964	1938	1680	1563	1310	1075	974	
2600	3014	2720	2604	2433	2153	2043	2016	1748	1625	1362	1118	1013	
2700	3130	2825	2705	2526	2236	2122	2093	1815	1688	1415	1161	1052	
2800	3246	2929	2805	2620	2318	2200	2171	1882	1751	1467	1204	1091	
2900	3362	3034	2905	2714	2401	2279	2248	1949	1813	1519	1247	1130	
3000	3478	3139	3005	2807	2484	2357	2326	2016	1876	1572	1290	1169	

TYP 33 K, VK, VKS

t_1 / t_2 [°C]	90 / 70			75 / 65			70 / 55			55 / 45			
	t_r [°C]	15	20	22	15	20	22	15	20	22	15	20	22
Dĺžka [mm]	400	781	704	673	628	555	526	519	449	418	349	286	259
	500	976	880	842	786	694	658	649	562	522	436	357	323
	600	1171	1056	1010	943	833	790	779	674	626	524	429	388
	700	1367	1232	1178	1100	972	921	909	786	731	611	500	453
	800	1562	1408	1347	1257	1110	1053	1039	899	835	698	571	517
	900	1757	1583	1515	1414	1249	1185	1169	1011	940	786	643	582
	1000	1952	1759	1684	1571	1388	1316	1298	1124	1044	873	714	647
	1100	2148	1935	1852	1728	1527	1448	1428	1236	1148	960	786	711
	1200	2343	2111	2020	1885	1666	1579	1558	1348	1253	1047	857	776
	1300	2538	2287	2189	2043	1804	1711	1688	1461	1357	1135	929	841
	1400	2733	2463	2357	2200	1943	1843	1818	1573	1462	1222	1000	905
	1500	2929	2639	2525	2357	2082	1974	1948	1685	1566	1309	1071	970
	1600	3124	2815	2694	2514	2221	210						

TYPY RADIÁTOROV

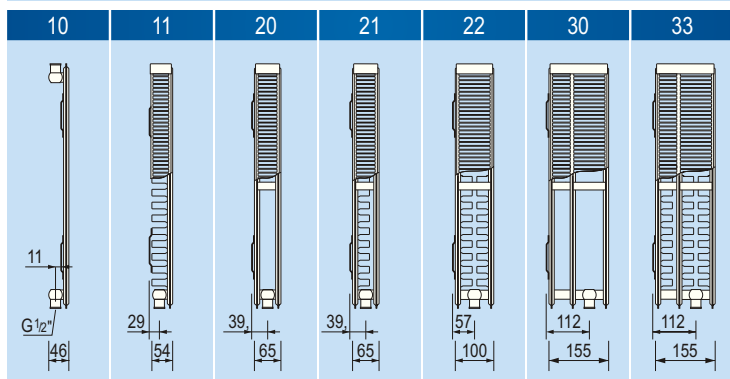

ZÁKLADNÉ TECHNICKÉ ÚDAJE

	Typ radiátora						
	10	11	20	21	22	30	33
M_T^K [kg·m ⁻¹]	8,60	13,70	17,70	19,46	22,99	27,39	33,97
M_T^{VK} [kg·m ⁻¹]	8,84	13,94	17,94	19,70	23,22	27,61	34,19
V_T [dm ³ ·m ⁻¹]	2,24	2,24	4,37	4,37	4,37	6,53	6,53
n [-]	1,3072	1,2953	1,2693	1,3338	1,3168	1,2939	1,3151

H - výška radiátora
 M_T^K - hmotnosť telesa radiátora Kompakt
 M_T^{VK} - hmotnosť telesa radiátora Ventil Kompakt
 V_T - vodný objem telesa
 n - exponent charakteristiky panelových radiátorov

TYP 10 K, VK, VKS

t_1 / t_2 [°C]	90 / 70			75 / 65			70 / 55			55 / 45		
	15	20	22	15	20	22	15	20	22	15	20	22
400	250	225	215	201	177	168	166	143	133	111	91	82
500	312	281	269	251	222	210	207	179	166	139	114	103
600	375	337	323	301	266	252	249	215	200	167	136	123
700	437	394	376	351	310	294	290	251	233	195	159	144
800	499	450	430	401	354	336	331	287	266	222	182	164
900	562	506	484	452	399	378	373	322	299	250	204	185
1000	624	562	538	502	443	420	414	358	333	278	227	206
1100	687	618	592	552	487	462	456	394	366	306	250	226
1200	749	675	645	602	532	504	497	430	399	334	273	247
1300	812	731	699	652	576	546	539	466	433	361	295	267
1400	874	787	753	702	620	588	580	501	466	389	318	288
1500	936	843	807	753	665	630	621	537	499	417	341	308
1600	999	900	861	803	709	672	663	573	532	445	364	329
1700	1061	956	914	853	753	714	704	609	566	472	386	350
1800	1124	1012	968	903	797	756	746	645	599	500	409	370
1900	1186	1068	1022	953	842	798	787	681	632	528	432	391
2000	1248	1124	1076	1004	886	840	829	716	665	556	454	411
2100	1311	1181	1129	1054	930	882	870	752	699	584	477	432
2200	1373	1237	1183	1104	975	924	911	788	732	611	500	452
2300	1436	1293	1237	1154	1019	966	953	824	765	639	523	473
2400	1498	1349	1291	1204	1063	1008	994	860	799	667	545	493
2500	1561	1406	1345	1254	1108	1050	1036	896	832	695	568	514
2600	1623	1462	1398	1305	1152	1092	1077	931	865	723	591	535
2700	1685	1518	1452	1355	1196	1134	1119	967	898	750	613	555
2800	1748	1574	1506	1405	1240	1176	1160	1003	932	778	636	576
2900	1810	1630	1560	1455	1285	1218	1201	1039	965	806	659	596
3000	1873	1687	1614	1505	1329	1260	1243	1075	998	834	682	617

TYP 11 K, VK, VKS

t_1 / t_2 [°C]	90 / 70			75 / 65			70 / 55			55 / 45		
	15	20	22	15	20	22	15	20	22	15	20	22
400	387	349	334	312	276	261	258	223	208	174	142	129
500	484	436	418	390	345	327	322	279	259	217	178	161
600	581	524	501	468	413	392	387	335	311	260	213	193
700	677	611	585	546	482	457	451	391	363	304	249	225
800	774	698	668	624	551	523	516	447	415	347	284	258
900	871	785	752	702	620	588	580	502	467	391	320	290
1000	968	873	835	780	689	654	645	558	519	434	356	322
1100	1065	960	919	857	758	719	709	614	571	477	391	354
1200	1161	1047	1002	935	827	784	774	670	623	521	427	386
1300	1258	1134	1086	1013	896	850	838	726	674	564	462	419
1400	1355	1222	1169	1091	965	915	903	781	726	608	498	451
1500	1452	1309	1253	1169	1034	980	967	837	778	651	533	483
1600	1549	1396	1336	1247	1102	1046	1032	893	830	695	569	515
1700	1645	1483	1420	1325	1171	1111	1096	949	882	738	604	547
1800	1742	1571	1503	1403	1240	1176	1160	1005	934	781	640	580
1900	1839	1658	1587	1481	1309	1242	1225	1061	986	825	675	612
2000	1936	1745	1670	1559	1378	1307	1289	1116	1038	868	711	644
2100												
2200												
2300												
2400												
2500												
2600												
2700												
2800												
2900												
3000												

TYP 20 K, VK, VKS

t_1 / t_2 [°C]	90 / 70			75 / 65			70 / 55			55 / 45		
	15	20	22	15	20	22	15	20	22	15	20	22
400	389	351	337	315	279	265	261	227	211	177	146	132
500	486	439	421	393	349	331	327	284	264	222	182	165
600	583	527	505	472	418	397	392	340	317	266	219	198
700	681	615	589	551	488	463	457	397	370	310	255	232
800	778	703	673	629	558	529	522	454	422	355	292	265
900	875	791	757	708	627	596	588	510	475	399	328	298
1000	972	878	841	787	697	662	653	567	528	443	364	331
1100	1070	966	926	865	767	728	718	624	581	488	401	364
1200	1167	1054	1010	944	836	794	784	680	633	532	437	397
1300	1264	1142	1094	1023	906	860	849	737	686	576	474	430
1400	1361	1230	1178	1101	976	927	914	794	739	621	510	463
1500	1459	1318	1262	1180	1046	993	980	851	792	665	547	496
1600	1556	1406	1346	1259	1115	1059	1045	907	845	709	583	529
1700	1653	1493	1431	1337	1185	1125	1110	964	897	753	620	562
1800	1750	1581	1515	1416	1255	1191	1176	1021	950	798	656	595
1900	1848	1669	1599	1495	1324	1257	1241	1077	1003	842	692	628
2000	1945	1757	1683	1573	1394	1324	1306	1134	1056	886	729	662
2100	2042	1845	1767	1652	1464	1390	1371	1191	1109	931	765	695
2200	2139	1933	1851	1731	1533	1456	1437	1248	1161	975	802	728
2300	2237	2021	1935	1809	1603	1522	1502	1304	1214	1019	838	761
2400	2334	2108	2020	1888	1673	1588	1567	1361	1267	1064	875	794
2500	2431	2196	2104	1967	1743	1655	1633	1418	1320	1108	911	827
2600	2528	2284	2188	2045	1812	1721	1698	1474	1372	1152	948	860
2700	2626	2372	2272	2124	1882	1787	1763	1531	1425	1197	984	893
2800	2723	2460	2356	2203	1952	1853	1829	1588	1478	1241	1020	926
2900	2820	2548	2440	2281	2021	1919	1894	1645	1531	1285	1057	959
3000	2917	2635	2524	2360	2091	1985	1959	1701	1584	1330	1093	992

TYP 21 K, VK, VKS

t_1 / t_2 [°C]	90 / 70			75 / 65			70 / 55			55 / 45			
	15	20	22	15	20	22	15	20	22	15	20	22	
t_r [°C]													
Délka [mm]	400	532	478	457	426	375	355	350	302	280	233	190	171
	500	665	597	571	532	469	444	438	377	350	291	237	214
	600	798	717	685	638	562	532	525	453	420	349	284	257
	700	931	836	799	745	656	621	613	528	490	408	332	300
	800	1064	956	914	851	750	710	700	604	560	466	379	342
	900	1197	1075	1028	958	843	799	788	679	630	524	427	385
	1000	1330	1195	1142	1064	937	887	875	754	700	582	474	428
	1100	1463	1314	1256	1170	1031	976	963	830	770	641	521	471
	1200	1596	1434	1371	1277	1124	1065	1050	905	840	699	569	514
	1300	1728	1553	1485	1383	1218	1154	1138	981	910	757	616	557
	1400	1861	1673	1599	1490	1312	1242	1225	1056	980	815	664	599
	1500	1994	1792	1713	1596	1406	1331	1313	1132	1050	873	711	642
	1600	2127	1912	1827	1702	1499	1420	1400	1207	1119	932	759	685
	1700	2260	2031	1942	1809	1593	1508	1488	1282	1189	990	806	728
	1800	2393	2151	2056	1915	1687	1597	1575	1358	1259	1048	853	771
	1900	2526	2270	2170	2022	1780	1686	1663	1433	1329	1106	901	813
	2000	2659	2390	2284	2128	1874	1775	1750	1509	1399	1165	948	856
	2100	2792	2509	2398	2234	1968	1863	1838	1584	1469	1223	996	899
	2200	2925	2629	2513	2341	2061	1952	1925	1660	1539	1281	1043	942
	2300	3058	2748	2627	2447	2155	2041	2013	1735	1609	1339	1090	985
2400	3191	2868	2741	2554	2249	2130	2100	1811	1679	1397	1138	1027	
2500	3324	2987	2855	2660	2343	2218	2188	1886	1749	1456	1185	1070	
2600	3457	3107	2970	2766	2436	2307	2275	1961	1819	1514	1233	1113	
2700	3590	3226	3084	2873	2530	2396	2363	2037	1889	1572	1280	1156	
2800	3723	3346	3198	2979	2624	2485	2450	2112	1959	1630	1327	1199	
2900	3856	3465	3312	3086	2717	2573	2538	2188	2029	1689	1375	1242	
3000	3989	3585	3426	3192	2811	2662	2625	2263	2099	1747	1422	1284	

TYP 22 K, VK, VKS

t_1 / t_2 [°C]	90 / 70			75 / 65			70 / 55			55 / 45			
	15	20	22	15	20	22	15	20	22	15	20	22	
t_r [°C]													
Délka [mm]	400	697	627	600	559	493	467	461	398	370	308	252	228
	500	871	784	750	699	617	584	576	498	462	385	315	285
	600	1045	941	899	839	740	701	691	597	554	463	378	341
	700	1219	1097	1049	979	863	818	807	697	647	540	440	398
	800	1393	1254	1199	1118	986	935	922	796	739	617	503	455
	900	1568	1411	1349	1258	1110	1052	1037	896	832	694	566	512
	1000	1742	1568	1499	1398	1233	1168	1152	995	924	771	629	569
	1100	1916	1724	1649	1538	1356	1285	1268	1095	1017	848	692	626
	1200	2090	1881	1799	1677	1480	1402	1383	1195	1109	925	755	683
	1300	2264	2038	1949	1817	1603	1519	1498	1294	1201	1002	818	740
	1400	2439	2195	2099	1957	1726	1636	1613	1394	1294	1079	881	797
	1500	2613	2351	2249	2097	1850	1753	1729	1493	1386	1156	944	854
	1600	2787	2508	2399	2237	1973	1870	1844	1593	1479	1233	1007	910
	1700	2961	2665	2549	2376	2096	1986	1959	1692	1571	1311	1070	967
	1800	3135	2822	2698	2516	2219	2103	2074	1792	1663	1388	1133	1024
	1900	3309	2978	2848	2656	2343	2220	2190	1891	1756	1465	1196	1081
	2000	3484	3135	2998	2796	2466	2337	2305	1991	1848	1542	1259	1138
	2100	3658	3292	3148	2936	2589	2454	2420	2090	1941	1619	1321	1195
	2200	3832	3449	3298	3075	2713	2571	2535	2190	2033	1696	1384	1252
	2300	4006	3605	3448	3215	2836	2687	2651	2290	2126	1773	1447	1309
2400	4180	3762	3598	3355	2959	2804	2766	2389	2218	1850	1510	1366	
2500	4355	3919	3748	3495	3083	2921	2881	2489	2310	1927	1573	1423	
2600	4529	4076	3898	3634	3206	3038	2996	2588	2403	2004	1636	1479	
2700	4703	4232	4048	3774	3329	3155	3112	2688	2495	2081	1699	1536	
2800	4877	4389	4198	3914	3452	3272	3227	2787	2588	2158	1762	1593	
2900	5051	4546	4347	4054	3576	3389	3342	2887	2680	2236	1825	1650	
3000	5225	4703	4497	4194	3699	3505	3457	2986	2772	2313	1888	1707	

TYP 30 K, VK, VKS

t_1 / t_2 [°C]	90 / 70			75 / 65			70 / 55			55 / 45			
	15	20	22	15	20	22	15	20	22	15	20	22	
t_r [°C]													
Délka [mm]	400	586	529	506	472	418	396	391	338	315	263	216	195
	500	733	661	633	591	522	495	488	423	393	329	270	244
	600	880	793	759	709	626	594	586	508	472	395	323	293
	700	1026	925	886	827	731	693	684	592	550	461	377	342
	800	1173	1057	1012	945	835	792	782	677	629	526	431	391
	900	1319	1190	1139	1063	940	891	879	761	708	592	485	439
	1000	1466	1322	1265	1181	1044	990	977	846	786	658	539	488
	1100	1613	1454	1392	1299	1148	1089	1075	931	865	724	593	537
	1200	1759	1586	1518	1417	1253	1188	1172	1015	944	790	647	586
	1300	1906	1718	1645	1535	1357	1287	1270	1100	1022	855	701	635
	1400	2052	1850	1771	1653	1462	1386	1368	1184	1101	921	755	684
	1500	2199	1983	1898	1772	1566	1485	1465	1269	1180	987	809	732
	1600	2346	2115	2024	1890	1670	1584	1563	1354	1258	1053	863	781
	1700	2492	2247	2151	2008	1775	1683	1661	1438	1337	1119	916	830
	1800	2639	2379	2277	2126	1879	1783	1759	1523	1416	1185	970	879
	1900	2785	2511	2404	2244	1984	1882	1856	1607	1494	1250	1024	928
	2000	2932	2644	2530	2362	2088	1981	1954	1692	1573	1316	1078	977
	2100	3079	2776	2657	2480	2192	2080	2052	1777	1651	1382	1132	1025
	2200	3225	2908	2783	2598	2297	2179	2149	1861	1730	1448	1186	1074
	2300	3372	3040	2910	2716	2401	2278	2247	1946	1809	1514	1240	1123
2400	3518	3172	3036	2834	2506	2377	2345	2030	1887	1579	1294	1172	
2500	3665	3304	3163	2953	2610	2476	2442	2115	1966	1645	1348	1221	
2600	3812	3437	3289	3071	2714	2575	2540	2200	2045	1711	1402	1270	
2700	3958	3569	3416	3189	2819	2674	2638	2284	2123	1777	1456	1318	
2800	4105	3701	3542	3307	2923	2773	2735	2369	2202	1843	1509	1367	
2900	4251	3833	3669	3425	3028	2872	2833	2453	2281	1908	1563	1416	
3000	4398	3965	3795	3543	3132	2971	2931	2538	2359	1974	1617	1465	

TYP 33 K, VK, VKS

t_1 / t_2 [°C]	90 / 70			75 / 65			70 / 55			55 / 45			
	15	20	22	15	20	22	15	20	22	15	20	22	
t_r [°C]													
Délka [mm]	400	989	890	851	794	700	664	655	566	525	438	358	324
	500	1236	1113	1064	992	876	830	818	707	656	548	447	404
	600	1483	1335	1277	1191	1051	996	982	848	788	657	537	485
	700	1731	1558	1490	1389	1226	1162	1146	990	919	767	626	566
	800	1978	1780	1703	1588	1401	1328	1309	1131	1050	876	716	647
	900	2225	2003	1916	1786	1576	1494	1473	1273	1182	986	805	728
	1000	2472	2225	2128	1985	1751	1659	1637	1414	1313	1095	894	809
	1100	2720	2448	2341	2183	1926	1825	1800	1555	1444	1205	984	890
	1200	2967	2671	2554	2382	2101	1991	1964	1697	1575	1314	1073	971
	1300	3214	2893	2767	2580	2276	2157	2128	1838	1707	1424		

TYPY RADIÁTOROV

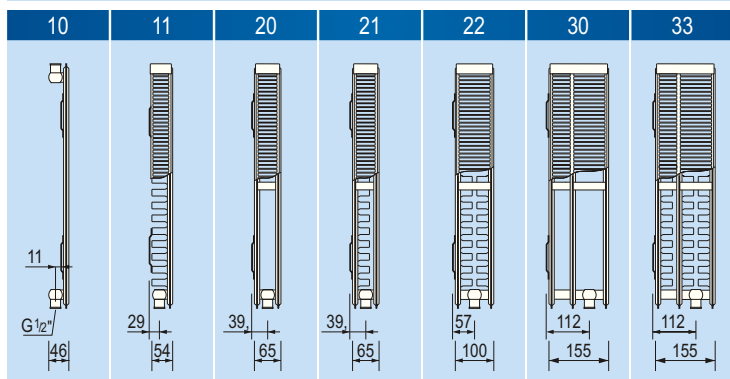

ZÁKLADNÉ TECHNICKÉ ÚDAJE

	Typ radiátora						
	10	11	20	21	22	30	33
M_T^K [kg·m ⁻¹]	10,60	17,05	21,30	23,98	27,60	33,17	40,70
M_T^{VK} [kg·m ⁻¹]	10,87	17,32	21,57	24,25	27,86	33,43	40,95
V_T [dm ³ ·m ⁻¹]	2,67	2,67	5,23	5,23	5,23	7,87	7,87
n [-]	1,2958	1,2994	1,2755	1,3437	1,3250	1,3048	1,3298
H	- výška radiátora						
M_T^K	- hmotnosť telesa radiátora Kompakt						
M_T^{VK}	- hmotnosť telesa radiátora Ventil Kompakt						
V_T	- vodný objem telesa						
n	- exponent charakteristiky panelových radiátorov						

TYP 10 K, VK, VKS

t_1 / t_2 [°C]	90 / 70			75 / 65			70 / 55			55 / 45		
	15	20	22	15	20	22	15	20	22	15	20	22
400	301	272	260	243	214	203	201	174	161	135	111	100
500	377	339	325	303	268	254	251	217	202	169	138	125
600	452	407	390	364	322	305	301	261	242	203	166	150
700	527	475	455	425	375	356	351	304	283	236	194	175
800	602	543	520	485	429	407	401	347	323	270	221	200
900	678	611	585	546	482	458	451	391	363	304	249	225
1000	753	679	650	606	536	508	502	434	404	338	276	250
1100	828	747	715	667	590	559	552	478	444	371	304	275
1200	904	815	780	728	643	610	602	521	484	405	332	301
1300	979	882	845	788	697	661	652	564	525	439	359	326
1400	1054	950	910	849	750	712	702	608	565	473	387	351
1500	1130	1018	974	910	804	763	752	651	605	506	415	376
1600	1205	1086	1039	970	858	813	802	695	646	540	442	401
1700	1280	1154	1104	1031	911	864	853	738	686	574	470	426
1800	1355	1222	1169	1092	965	915	903	782	726	608	498	451
1900	1431	1290	1234	1152	1018	966	953	825	767	641	525	476
2000	1506	1358	1299	1213	1072	1017	1003	868	807	675	553	501
2100	1581	1426	1364	1274	1126	1068	1053	912	848	709	581	526
2200	1657	1493	1429	1334	1179	1118	1103	955	888	743	608	551
2300	1732	1561	1494	1395	1233	1169	1154	999	928	777	636	576
2400	1807	1629	1559	1456	1286	1220	1204	1042	969	810	664	601
2500	1883	1697	1624	1516	1340	1271	1254	1086	1009	844	691	626
2600	1958	1765	1689	1577	1394	1322	1304	1129	1049	878	719	651
2700	2033	1833	1754	1637	1447	1373	1354	1172	1090	912	747	676
2800	2108	1901	1819	1698	1501	1423	1404	1216	1130	945	774	701
2900	2184	1969	1884	1759	1554	1474	1454	1259	1170	979	802	726
3000	2259	2037	1949	1819	1608	1525	1505	1303	1211	1013	829	751

TYP 11 K, VK, VKS

t_1 / t_2 [°C]	90 / 70			75 / 65			70 / 55			55 / 45		
	15	20	22	15	20	22	15	20	22	15	20	22
400	465	419	401	374	330	313	309	268	249	208	170	154
500	581	523	501	467	413	392	386	334	311	260	213	193
600	697	628	601	561	496	470	464	401	373	312	255	231
700	813	733	701	654	578	548	541	468	435	364	298	270
800	929	837	801	748	661	627	618	535	497	416	340	308
900	1045	942	902	841	743	705	695	602	559	468	383	347
1000	1162	1047	1002	935	826	783	773	669	621	520	425	385
1100	1278	1151	1102	1028	909	862	850	736	684	572	468	424
1200	1394	1256	1202	1122	991	940	927	803	746	624	510	462
1300	1510	1361	1302	1215	1074	1018	1005	869	808	676	553	501
1400	1626	1466	1402	1309	1156	1097	1082	936	870	727	595	539
1500	1742	1570	1503	1402	1239	1175	1159	1003	932	779	638	578
1600	1858	1675	1603	1496	1322	1253	1236	1070	994	831	681	616
1700	1975	1780	1703	1589	1404	1332	1314	1137	1056	883	723	655
1800	2091	1884	1803	1683	1487	1410	1391	1204	1119	935	766	693
1900	2207	1989	1903	1776	1569	1488	1468	1271	1181	987	808	732
2000	2323	2094	2003	1870	1652	1567	1545	1338	1243	1039	851	770
2100												
2200												
2300												
2400												
2500												
2600												
2700												
2800												
2900												
3000												

TYP 20 K, VK, VKS

t_1 / t_2 [°C]	90 / 70			75 / 65			70 / 55			55 / 45		
	15	20	22	15	20	22	15	20	22	15	20	22
400	465	420	402	376	333	316	312	270	252	211	173	157
500	581	525	503	470	416	395	390	338	315	264	217	197
600	698	630	603	564	499	474	468	406	378	317	260	236
700	814	735	704	658	582	553	546	473	440	370	304	275
800	930	840	804	752	666	632	623	541	503	422	347	315
900	1046	945	905	846	749	711	701	609	566	475	390	354
1000	1163	1050	1005	940	832	790	779	676	629	528	434	393
1100	1279	1155	1106	1034	915	869	857	744	692	581	477	433
1200	1395	1260	1206	1127	998	948	935	811	755	633	520	472
1300	1511	1365	1307	1221	1082	1027	1013	879	818	686	564	511
1400	1628	1470	1408	1315	1165	1106	1091	947	881	739	607	551
1500	1744	1575	1508	1409	1248	1185	1169	1014	944	792	650	590
1600	1860	1680	1609	1503	1331	1264	1247	1082	1007	845	694	629
1700	1977	1785	1709	1597	1414	1343	1325	1150	1070	897	737	669
1800	2093	1890	1810	1691	1498	1422	1403	1217	1133	950	781	708
1900	2209	1995	1910	1785	1581	1501	1481	1285	1196	1003	824	747
2000	2325	2100	2011	1879	1664	1580	1559	1352	1258	1056	867	787
2100	2442	2205	2111	1973	1747	1659	1637	1420	1321	1109	911	826
2200	2558	2310	2212	2067	1830	1738	1714	1488	1384	1161	954	865
2300	2674	2415	2312	2161	1914	1817	1792	1555	1447	1214	997	905
2400	2790	2520	2413	2255	1997	1895	1870	1623	1510	1267	1041	944
2500	2907	2625	2514	2349	2080	1974	1948	1691	1573	1320	1084	983
2600	3023	2730	2614	2443	2163	2053	2026	1758	1636	1373	1128	1023
2700	3139	2835	2715	2537	2246	2132	2104	1826	1699	1425	1171	1062
2800	3255	2940	2815	2631	2330	2211	2182	1893	1762	1478	1214	1101
2900	3372	3045	2916	2725	2413	2290	2260	1961	1825	1531	1258	1141
3000	3488	3149	3016	2819	2496	2369	2338	2029	1888	1584	1301	1180

TYP 21 K, VK, VKS

t_1 / t_2 [°C]	90 / 70			75 / 65			70 / 55			55 / 45		
	15	20	22	15	20	22	15	20	22	15	20	22
400	635	570	544	507	446	422	416	359	332	276	225	203
500	793	712	681	634	558	528	520	448	415	345	281	253
600	952	855	817	760	669	633	624	538	498	414	337	304
700	1110	997	953	887	781	739	729	627	582	483	393	355
800	1269	1140	1089	1014	892	844	833	717	665	552	449	405
900	1428	1282	1225	1141	1004	950	937	807	748	621	505	456
1000	1586	1425	1361	1267	1115	1055	1041	896	831	690	561	506
1100	1745	1567	1497	1394	1227	1161	1145	986	914	759	617	557
1200	1904	1709	1633	1521	1338	1267	1249	1076	997	829	674	608
1300	2062	1852	1769	1648	1450	1372	1353	1165	1080	898	730	658
1400	2221	1994	1906	1774	1561	1478	1457	1255	1163	967	786	709
1500	2379	2137	2042	1901	1673	1583	1561	1344	1246	1036	842	760
1600	2538	2279	2178	2028	1784	1689	1665	1434	1329	1105	898	810
1700	2697	2422	2314	2154	1896	1794	1769	1524	1412	1174	954	861
1800	2855	2564	2450	2281	2007	1900	1873	1613	1495	1243	1010	912
1900	3014	2707	2586	2408	2119	2005	1977	1703	1578	1312	1066	962
2000	3173	2849	2722	2535	2230	2111	2081	1793	1662	1381	1123	1013
2100	3331	2992	2858	2661	2342	2217	2186	1882	1745	1450	1179	1064
2200	3490	3134	2994	2788	2453	2322	2290	1972	1828	1519	1235	1114
2300	3648	3276	3131	2915	2565	2428	2394	2061	1911	1588	1291	1165
2400	3807	3419	3267	3042	2676	2533	2498	2151	1994	1657	1347	1216
2500	3966	3561	3403	3168	2788	2639	2602	2241	2077	1726	1403	1266
2600	4124	3704	3539	3295	2899	2744	2706	2330	2160	1795	1459	1317
2700	4283	3846	3675	3422	3011	2850	2810	2420	2243	1864	1515	1368
2800	4442	3989	3811	3549	3122	2955	2914	2510	2326	1933	1572	1418
2900	4600	4131	3947	3675	3234	3061	3018	2599	2409	2002	1628	1469
3000	4759	4274	4083	3802	3345	3166	3122	2689	2492	2071	1684	1519

TYP 22 K, VK, VKS

t_1 / t_2 [°C]	90 / 70			75 / 65			70 / 55			55 / 45		
	15	20	22	15	20	22	15	20	22	15	20	22
400	832	749	716	667	588	557	549	474	440	367	299	270
500	1041	936	895	834	735	696	687	593	550	458	374	338
600	1249	1123	1074	1001	882	836	824	711	660	550	448	405
700	1457	1310	1253	1168	1029	975	961	830	770	641	523	473
800	1665	1497	1432	1334	1176	1114	1099	948	880	733	598	540
900	1873	1685	1611	1501	1323	1253	1236	1067	990	825	672	608
1000	2081	1872	1789	1668	1470	1393	1373	1185	1100	916	747	675
1100	2289	2059	1968	1835	1617	1532	1511	1304	1210	1008	822	743
1200	2497	2246	2147	2001	1764	1671	1648	1422	1320	1100	896	810
1300	2705	2433	2326	2168	1911	1810	1785	1541	1430	1191	971	878
1400	2914	2620	2505	2335	2058	1950	1923	1659	1540	1283	1046	945
1500	3122	2808	2684	2502	2205	2089	2060	1778	1650	1375	1121	1013
1600	3330	2995	2863	2669	2352	2228	2197	1896	1760	1466	1195	1080
1700	3538	3182	3042	2835	2499	2367	2335	2015	1870	1558	1270	1148
1800	3746	3369	3221	3002	2646	2507	2472	2133	1980	1649	1345	1215
1900	3954	3556	3400	3169	2793	2646	2609	2252	2090	1741	1419	1283
2000	4162	3743	3579	3336	2940	2785	2747	2370	2200	1833	1494	1350
2100	4370	3931	3758	3503	3087	2924	2884	2489	2310	1924	1569	1418
2200	4578	4118	3937	3669	3234	3064	3022	2607	2420	2016	1644	1485
2300	4787	4305	4116	3836	3381	3203	3159	2726	2530	2108	1718	1553
2400	4995	4492	4295	4003	3528	3342	3296	2845	2639	2199	1793	1620
2500	5203	4679	4474	4170	3675	3482	3434	2963	2749	2291	1868	1688
2600	5411	4866	4653	4336	3822	3621	3571	3082	2859	2383	1942	1755
2700	5619	5054	4832	4503	3969	3760	3708	3200	2969	2474	2017	1823
2800	5827	5241	5011	4670	4116	3899	3846	3319	3079	2566	2092	1890
2900	6035	5428	5189	4837	4263	4039	3983	3437	3189	2657	2167	1958
3000	6243	5615	5368	5004	4410	4178	4120	3556	3299	2749	2241	2025

TYP 30 K, VK, VKS

t_1 / t_2 [°C]	90 / 70			75 / 65			70 / 55			55 / 45		
	15	20	22	15	20	22	15	20	22	15	20	22
400	706	636	608	568	501	475	469	405	377	315	257	233
500	882	795	760	709	627	594	586	507	471	393	322	291
600	1059	954	912	851	752	713	703	608	565	472	386	349
700	1235	1113	1065	993	877	832	820	710	659	551	450	408
800	1412	1272	1217	1135	1002	950	938	811	753	629	515	466
900	1588	1431	1369	1277	1128	1069	1055	912	847	708	579	524
1000	1765	1590	1521	1419	1253	1188	1172	1014	942	787	643	582
1100	1941	1748	1673	1561	1378	1307	1289	1115	1036	865	708	641
1200	2117	1907	1825	1703	1504	1426	1406	1216	1130	944	772	699
1300	2294	2066	1977	1845	1629	1544	1523	1318	1224	1023	836	757
1400	2470	2225	2129	1986	1754	1663	1641	1419	1318	1101	901	815
1500	2647	2384	2281	2128	1880	1782	1758	1520	1412	1180	965	874
1600	2823	2543	2433	2270	2005	1901	1875	1622	1507	1259	1029	932
1700	3000	2702	2585	2412	2130	2020	1992	1723	1601	1337	1094	990
1800	3176	2861	2737	2554	2255	2138	2109	1824	1695	1416	1158	1048
1900	3353	3020	2889	2696	2381	2257	2227	1926	1789	1495	1222	1106
2000	3529	3179	3041	2838	2506	2376	2344	2027	1883	1573	1287	1165
2100	3705	3338	3194	2980	2631	2495	2461	2129	1977	1652	1351	1223
2200	3882	3497	3346	3122	2757	2614	2578	2230	2072	1731	1415	1281
2300	4058	3656	3498	3264	2882	2732	2695	2331	2166	1810	1480	1339
2400	4235	3815	3650	3405	3007	2851	2813	2433	2260	1888	1544	1398
2500	4411	3974	3802	3547	3133	2970	2930	2534	2354	1967	1609	1456
2600	4588	4133	3954	3689	3258	3089	3047	2635	2448	2046	1673	1514
2700	4764	4292	4106	3831	3383	3208	3164	2737	2542	2124	1737	1572
2800	4941	4451	4258	3973	3508	3326	3281	2838	2636	2203	1802	1631
2900	5117	4610	4410	4115	3634	3445	3398	2939	2731	2282	1866	1689
3000	5294	4769	4562	4257	3759	3564	3516	3041	2825	2360	1930	1747

TYP 33 K, VK, VKS

t_1 / t_2 [°C]	90 / 70			75 / 65			70 / 55			55 / 45		
	15	20	22	15	20	22	15	20	22	15	20	22
400	1186	1066	1019	949	836	792	781	674	625	521	424	383
500	1482	1332	1274	1187	1046	990	977	842	781	651	530	479
600	1778	1599	1528	1424	1255	1188	1172	1011	938	781	636	575
700	2075	1865	1783	1661	1464	1386	1367	1179	1094	911	742	670
800	2371	2132	2038	1899	1673	1584	1563	1348	1250	1041	848	766
900	2668	2398	2293	2136	1882	1782	1758	1516	1406	1171	954	862
1000	2964	2665	2547	2374	2091	1981	1953	1685	1563	1301	1060	958
1100	3260	2931	2802	2611	2300	2179	2148	1853	1719	1431	1166	1053
1200	3557	3198	3057	2848	2509	2377	2344	2022	1875	1562	1272	1149
1300	3853	3464	3311	3086	2718	2575	2539	2190	2032	1692	1378	1245
1400	4150	3731	3566	3323	2927	2773	2734	2358	2188	1822	1484	1341
1500	4446	3997	3821	3560	3137	2971	2930	2527	2344	1952</		

TYPY RADIÁTOROV

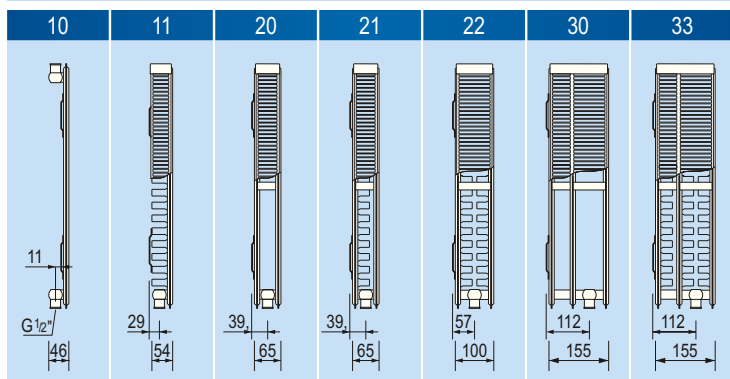

ZÁKLADNÉ TECHNICKÉ ÚDAJE

	Typ radiátora						
	10	11	20	21	22	30	33
M_T^K [kg.m ⁻¹]	11,70	-	23,55	27,00	31,20	35,95	46,05
M_T^{VK} [kg.m ⁻¹]	-	-	-	-	-	-	-
V_T [dm ³ .m ⁻¹]	2,80	-	5,30	5,30	5,30	8,15	8,15
n [-]	1,3145	-	1,2776	1,3030	1,3413	1,3053	1,3357
H - výška radiátora M_T^K - hmotnosť telesa radiátora Kompakt M_T^{VK} - hmotnosť telesa radiátora Ventil Kompakt V_T - vodný objem telesa n - exponent charakteristiky panelových radiátorov							

TYP 10

t_1 / t_2 [°C]	90 / 70			75 / 65			70 / 55			55 / 45		
	15	20	22	15	20	22	15	20	22	15	20	22
400	329	296	283	264	233	221	218	188	175	146	119	108
500	412	370	354	330	292	276	272	235	219	182	149	135
600	494	445	425	396	350	332	327	283	262	219	179	162
700	576	519	496	463	408	387	381	330	306	255	209	189
800	658	593	567	529	466	442	436	377	350	292	238	216
900	741	667	638	595	525	497	490	424	393	328	268	242
1000	823	741	709	661	583	553	545	471	437	365	298	269
1100												
1200	988	889	850	793	700	663	654	565	525	438	357	323
1300												
1400	1152	1037	992	925	816	774	763	659	612	511	417	377
1500												
1600	1317	1185	1134	1057	933	884	872	753	699	584	477	431
1700												
1800	1482	1334	1275	1189	1049	995	981	848	787	657	536	485
1900												
2000	1646	1482	1417	1322	1166	1105	1090	942	874	730	596	539
2100												
2200												
2300												
2400												
2500												
2600												
2700												
2800												
2900												
3000												

TYP 11 K

t_1 / t_2 [°C]	90 / 70			75 / 65			70 / 55			55 / 45		
	15	20	22	15	20	22	15	20	22	15	20	22
400												
500												
600												
700												
800												
900												
1000												
1100												
1200												
1300												
1400												
1500												
1600												
1700												
1800												
1900												
2000												
2100												
2200												
2300												
2400												
2500												
2600												
2700												
2800												
2900												
3000												

Radiátor typu 11 s výškou 550 mm sa nevyrába !

TYP 20 K

t_1 / t_2 [°C]	90 / 70			75 / 65			70 / 55			55 / 45		
	15	20	22	15	20	22	15	20	22	15	20	22
400	506	456	437	408	362	343	339	294	273	229	188	171
500	632	571	546	511	452	429	423	367	342	287	235	213
600	758	685	656	613	542	515	508	441	410	344	282	256
700	885	799	765	715	633	601	593	514	478	401	329	299
800	1011	913	874	817	723	686	677	588	547	459	377	342
900	1138	1027	983	919	814	772	762	661	615	516	424	384
1000	1264	1141	1093	1021	904	858	847	735	683	573	471	427
1100												
1200	1517	1369	1311	1225	1085	1030	1016	881	820	688	565	512
1300												
1400	1770	1598	1530	1429	1266	1201	1185	1028	957	802	659	598
1500												
1600	2022	1826	1748	1634	1446	1373	1355	1175	1093	917	753	683
1700												
1800	2275	2054	1967	1838	1627	1545	1524	1322	1230	1032	847	768
1900												
2000	2528	2282	2185	2042	1808	1716	1693	1469	1367	1146	941	854
2100												
2200												
2300												
2400												
2500												
2600												
2700												
2800												
2900												
3000												

TYP 21 K

t_1 / t_2 [°C]	90 / 70			75 / 65			70 / 55			55 / 45		
	t_r [°C]	15	20	22	15	20	22	15	20	22	15	20
400	687	617	590	549	483	457	451	389	360	299	244	220
500	859	771	737	686	604	572	564	486	450	374	304	275
600	1031	926	884	824	725	686	677	583	540	449	365	330
700	1202	1080	1032	961	846	801	789	680	630	524	426	385
800	1374	1234	1179	1098	966	915	902	777	720	599	487	440
900	1546	1388	1327	1235	1087	1029	1015	874	810	674	548	495
1000	1718	1543	1474	1373	1208	1144	1128	971	901	749	609	550
1100												
1200	2061	1851	1769	1647	1450	1372	1353	1166	1081	898	731	659
1300												
1400	2405	2160	2064	1922	1691	1601	1579	1360	1261	1048	852	769
1500												
1600	2748	2468	2359	2196	1933	1830	1804	1554	1441	1198	974	879
1700												
1800	3092	2777	2653	2471	2174	2059	2030	1749	1621	1348	1096	989
1900												
2000	3435	3085	2948	2745	2416	2287	2255	1943	1801	1497	1218	1099
2100												
2200	3779	3394	3243	3020	2658	2516	2481	2137	1981	1647	1339	1209
2300												
2400	4122	3702	3538	3295	2899	2745	2706	2331	2161	1797	1461	1319
2500												
2600	4466	4011	3833	3569	3141	2973	2932	2526	2341	1947	1583	1429
2700												
2800	4809	4319	4127	3844	3382	3202	3158	2720	2522	2096	1705	1539
2900												
3000	5153	4628	4422	4118	3624	3431	3383	2914	2702	2246	1827	1649

TYP 22 K

t_1 / t_2 [°C]	90 / 70			75 / 65			70 / 55			55 / 45		
	t_r [°C]	15	20	22	15	20	22	15	20	22	15	20
400	903	812	776	723	638	604	596	514	477	397	324	293
500	1128	1015	970	904	797	755	745	643	596	497	405	366
600	1354	1218	1164	1085	956	906	894	771	716	596	486	439
700	1580	1421	1358	1266	1116	1057	1042	900	835	696	567	512
800	1805	1624	1552	1447	1275	1208	1191	1028	954	795	648	586
900	2031	1827	1746	1628	1435	1359	1340	1157	1073	894	729	659
1000	2257	2030	1940	1809	1594	1510	1489	1285	1193	994	810	732
1100												
1200	2708	2435	2328	2170	1913	1812	1787	1542	1431	1192	972	879
1300												
1400	3159	2841	2717	2532	2232	2114	2085	1799	1670	1391	1134	1025
1500												
1600	3611	3247	3105	2894	2550	2416	2383	2056	1908	1590	1296	1171
1700												
1800	4062	3653	3493	3255	2869	2718	2681	2313	2147	1789	1458	1318
1900												
2000	4513	4059	3881	3617	3188	3020	2979	2570	2385	1987	1620	1464
2100												
2200	4964	4465	4269	3979	3507	3322	3276	2827	2624	2186	1782	1611
2300												
2400	5416	4871	4657	4341	3826	3624	3574	3085	2862	2385	1944	1757
2500												
2600	5867	5277	5045	4702	4144	3926	3872	3342	3101	2584	2106	1904
2700												
2800	6318	5683	5433	5064	4463	4228	4170	3599	3339	2782	2268	2050
2900												
3000	6770	6089	5821	5426	4782	4530	4468	3856	3578	2981	2430	2196

TYP 30 K

t_1 / t_2 [°C]	90 / 70			75 / 65			70 / 55			55 / 45		
	t_r [°C]	15	20	22	15	20	22	15	20	22	15	20
400	768	692	662	617	545	517	510	441	410	342	280	253
500	960	865	827	772	682	646	637	551	512	428	350	317
600	1152	1038	993	926	818	775	765	661	614	513	420	380
700	1344	1210	1158	1080	954	905	892	772	717	599	490	443
800	1536	1383	1323	1235	1090	1034	1020	882	819	685	560	507
900	1728	1556	1489	1389	1227	1163	1147	992	922	770	630	570
1000	1920	1729	1654	1544	1363	1292	1275	1102	1024	856	700	633
1100												
1200	2304	2075	1985	1852	1636	1551	1530	1323	1229	1027	840	760
1300												
1400	2688	2421	2316	2161	1908	1809	1785	1543	1434	1198	980	887
1500												
1600	3071	2767	2647	2470	2181	2068	2040	1764	1639	1369	1120	1013
1700												
1800	3455	3113	2978	2778	2453	2326	2295	1984	1843	1540	1259	1140
1900												
2000	3839	3458	3309	3087	2726	2585	2549	2205	2048	1711	1399	1267
2100												
2200												
2300												
2400												
2500												
2600												
2700												
2800												
2900												
3000												

TYP 33 K

t_1 / t_2 [°C]	90 / 70			75 / 65			70 / 55			55 / 45		
	t_r [°C]	15	20	22	15	20	22	15	20	22	15	20
400	1286	1156	1105	1029	906	858	846	729	676	563	458	413
500	1608	1445	1381	1286	1133	1072	1058	912	845	703	572	517
600	1929	1734	1657	1544	1359	1287	1269	1094	1014	844	687	620
700	2251	2023	1933	1801	1586	1501	1481	1276	1183	985	801	724
800	2572	2312	2209	2058	1812	1716	1692	1458	1352	1125	916	827
900	2894	2601	2485	2315	2039	1930	1904	1641	1522	1266	1030	930
1000	3216	2890	2762	2573	2265	2145	2115	1823	1691	1407	1145	1034
1100												
1200	3859	3467	3314	3087	2718	2574	2538	2188	2029	1688	1374	1240
1300												
1400	4502	4045	3866	3602	3171	3003	2961	2552	2367	1969	1603	1447
1500												
1600	5145	4623	4419	4116	3624	3432	3384	2917	2705	2251	1832	1654
1700												
1800	5788	5201	4971	4631	4077	3861	3807	3281	3043	2532	2061	1861
1900												
2000	6431	5779	5523	5145	4530	4290	4230	3646	3381	2813	2290	2067
2100												
2200												
2300												
2400												
2500												
2600												
2700												
2800												
2900												
3000												

TYPY RADIÁTOROV

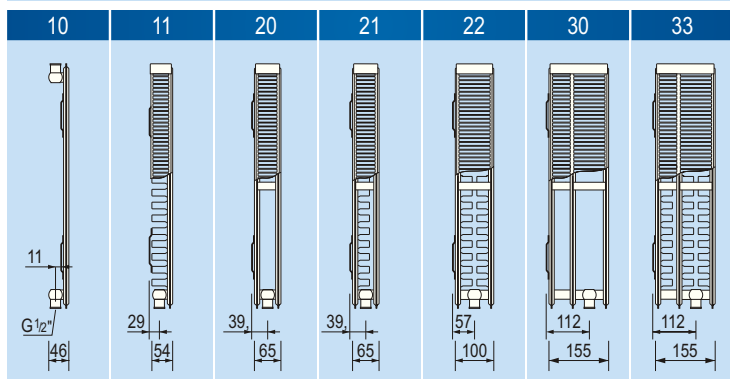

ZÁKLADNÉ TECHNICKÉ ÚDAJE

	Typ radiátora						
	10	11	20	21	22	30	33
M_T^K [kg·m ⁻¹]	12,53	19,95	25,45	28,50	32,75	38,96	48,72
M_T^{VK} [kg·m ⁻¹]	12,83	20,25	25,76	28,81	33,03	39,25	49,00
V_T [dm ³ ·m ⁻¹]	3,10	3,10	6,10	6,10	6,10	9,20	9,20
n [-]	1,2843	1,3035	1,2818	1,3536	1,3331	1,3156	1,3444
H	- výška radiátora						
M_T^K	- hmotnosť telesa radiátora Kompakt						
M_T^{VK}	- hmotnosť telesa radiátora Ventil Kompakt						
V_T	- vodný objem telesa						
n	- exponent charakteristiky panelových radiátorov						

TYP 10 K, VK, VKS

t_1 / t_2 [°C]	90 / 70			75 / 65			70 / 55			55 / 45		
	15	20	22	15	20	22	15	20	22	15	20	22
400	348	314	301	281	248	236	233	202	188	157	129	117
500	435	392	376	351	311	295	291	252	234	196	161	146
600	522	471	451	421	373	354	349	302	281	236	193	175
700	609	549	526	491	435	412	407	353	328	275	226	204
800	696	628	601	561	497	471	465	403	375	314	258	234
900	783	706	676	632	559	530	523	454	422	354	290	263
1000	870	785	751	702	621	589	581	504	469	393	322	292
1100	957	863	827	772	683	648	640	554	516	432	354	321
1200	1044	942	902	842	745	707	698	605	563	471	387	351
1300	1131	1020	977	912	807	766	756	655	609	511	419	380
1400	1218	1099	1052	983	869	825	814	706	656	550	451	409
1500	1305	1177	1127	1053	932	884	872	756	703	589	483	438
1600	1392	1256	1202	1123	994	943	930	806	750	628	516	467
1700	1479	1334	1277	1193	1056	1002	988	857	797	668	548	497
1800	1566	1413	1353	1263	1118	1061	1047	907	844	707	580	526
1900	1653	1491	1428	1334	1180	1120	1105	958	891	746	612	555
2000	1740	1570	1503	1404	1242	1179	1163	1008	938	786	644	584
2100	1827	1648	1578	1474	1304	1237	1221	1058	984	825	677	613
2200	1914	1727	1653	1544	1366	1296	1279	1109	1031	864	709	643
2300	2001	1805	1728	1614	1428	1355	1337	1159	1078	903	741	672
2400	2088	1884	1803	1684	1490	1414	1395	1210	1125	943	773	701
2500	2175	1962	1879	1755	1553	1473	1454	1260	1172	982	806	730
2600	2262	2041	1954	1825	1615	1532	1512	1310	1219	1021	838	759
2700	2349	2119	2029	1895	1677	1591	1570	1361	1266	1061	870	789
2800	2435	2198	2104	1965	1739	1650	1628	1411	1313	1100	902	818
2900	2522	2276	2179	2035	1801	1709	1686	1462	1359	1139	934	847
3000	2609	2355	2254	2106	1863	1768	1744	1512	1406	1178	967	876

TYP 11 K, VK, VKS

t_1 / t_2 [°C]	90 / 70			75 / 65			70 / 55			55 / 45		
	15	20	22	15	20	22	15	20	22	15	20	22
400	541	487	466	435	384	364	359	311	289	241	197	179
500	676	609	582	543	480	455	449	388	361	302	247	223
600	811	731	699	652	576	546	539	466	433	362	296	268
700	946	852	815	761	672	637	629	544	505	422	345	313
800	1081	974	932	870	768	728	718	621	577	482	395	357
900	1216	1096	1048	978	864	819	808	699	649	543	444	402
1000	1351	1218	1165	1087	960	910	898	777	722	603	493	447
1100	1487	1339	1281	1196	1056	1001	988	854	794	663	543	491
1200	1622	1461	1398	1304	1152	1092	1077	932	866	724	592	536
1300	1757	1583	1514	1413	1248	1183	1167	1010	938	784	641	580
1400	1892	1705	1631	1522	1344	1274	1257	1087	1010	844	691	625
1500	2027	1826	1747	1630	1440	1365	1347	1165	1082	905	740	670
1600	2162	1948	1864	1739	1536	1456	1437	1243	1155	965	789	714
1700	2297	2070	1980	1848	1632	1547	1526	1320	1227	1025	839	759
1800	2433	2192	2097	1957	1728	1638	1616	1398	1299	1085	888	804
1900	2568	2313	2213	2065	1824	1729	1706	1476	1371	1146	937	848
2000	2703	2435	2330	2174	1920	1821	1796	1553	1443	1206	987	893
2100												
2200												
2300												
2400												
2500												
2600												
2700												
2800												
2900												
3000												

TYP 20 K, VK, VKS

t_1 / t_2 [°C]	90 / 70			75 / 65			70 / 55			55 / 45		
	15	20	22	15	20	22	15	20	22	15	20	22
400	541	488	467	437	386	367	362	314	292	245	201	182
500	676	610	584	546	483	458	452	392	365	306	251	228
600	811	732	701	655	580	550	543	471	438	367	301	273
700	947	854	818	764	676	642	633	549	511	428	351	319
800	1082	976	935	873	773	733	724	627	584	489	402	364
900	1217	1098	1052	982	869	825	814	706	657	550	452	410
1000	1352	1220	1168	1092	966	917	905	784	730	612	502	455
1100	1487	1342	1285	1201	1063	1008	995	863	803	673	552	501
1200	1623	1464	1402	1310	1159	1100	1085	941	876	734	602	546
1300	1758	1586	1519	1419	1256	1192	1176	1020	948	795	652	592
1400	1893	1708	1636	1528	1352	1283	1266	1098	1021	856	703	637
1500	2028	1830	1753	1637	1449	1375	1357	1177	1094	917	753	683
1600	2163	1953	1869	1746	1546	1467	1447	1255	1167	978	803	728
1700	2299	2075	1986	1856	1642	1558	1538	1333	1240	1040	853	774
1800	2434	2197	2103	1965	1739	1650	1628	1412	1313	1101	903	819
1900	2569	2319	2220	2074	1835	1742	1719	1490	1386	1162	954	865
2000	2704	2441	2337	2183	1932	1834	1809	1569	1459	1223	1004	910
2100	2840	2563	2454	2292	2029	1925	1900	1647	1532	1284	1054	956
2200	2975	2685	2571	2401	2125	2017	1990	1726	1605	1345	1104	1001
2300	3110	2807	2687	2511	2222	2109	2080	1804	1678	1407	1154	1047
2400	3245	2929	2804	2620	2318	2200	2171	1882	1751	1468	1205	1092
2500	3380	3051	2921	2729	2415	2292	2261	1961	1824	1529	1255	1138
2600	3516	3173	3038	2838	2512	2384	2352	2039	1897	1590	1305	1183
2700	3651	3295	3155	2947	2608	2475	2442	2118	1970	1651	1355	1229
2800	3786	3417	3272	3056	2705	2567	2533	2196	2043	1712	1405	1274
2900	3921	3539	3388	3165	2801	2659	2623	2275	2116	1773	1455	1320
3000	4056	3661	3505	3275	2898	2750	2714	2353	2189	1835	1506	1365

TYP 21 K, VK, VKS

Délka [mm]	t_1 / t_2 [°C]	90 / 70			75 / 65			70 / 55			55 / 45		
		t_r [°C]	15	20	22	15	20	22	15	20	22	15	20
400	400	734	659	629	586	515	487	480	413	383	318	258	232
500	400	918	824	787	732	644	609	600	516	478	397	322	291
600	400	1101	988	944	879	772	731	720	620	574	476	387	349
700	400	1285	1153	1101	1025	901	852	840	723	670	556	451	407
800	400	1469	1318	1259	1171	1030	974	961	826	765	635	516	465
900	400	1652	1483	1416	1318	1158	1096	1081	930	861	715	580	523
1000	400	1836	1647	1573	1464	1287	1218	1201	1033	957	794	645	581
1100	400	2019	1812	1731	1611	1416	1340	1321	1136	1053	874	709	639
1200	400	2203	1977	1888	1757	1544	1461	1441	1239	1148	953	774	697
1300	400	2386	2141	2045	1903	1673	1583	1561	1343	1244	1032	838	756
1400	400	2570	2306	2203	2050	1802	1705	1681	1446	1340	1112	902	814
1500	400	2754	2471	2360	2196	1931	1827	1801	1549	1435	1191	967	872
1600	400	2937	2636	2517	2343	2059	1949	1921	1653	1531	1271	1031	930
1700	400	3121	2800	2675	2489	2188	2070	2041	1756	1627	1350	1096	988
1800	400	3304	2965	2832	2636	2317	2192	2161	1859	1722	1429	1160	1046
1900	400	3488	3130	2989	2782	2445	2314	2281	1962	1818	1509	1225	1104
2000	400	3671	3294	3147	2928	2574	2436	2401	2066	1914	1588	1289	1162
2100	400	3855	3459	3304	3075	2703	2557	2521	2169	2009	1668	1354	1221
2200	400	4039	3624	3461	3221	2831	2679	2641	2272	2105	1747	1418	1279
2300	400	4222	3789	3619	3368	2960	2801	2762	2376	2201	1827	1483	1337
2400	400	4406	3953	3776	3514	3089	2923	2882	2479	2296	1906	1547	1395
2500	400	4589	4118	3933	3661	3218	3045	3002	2582	2392	1985	1611	1453
2600	400	4773	4283	4091	3807	3346	3166	3122	2685	2488	2065	1676	1511
2700	400	4957	4448	4248	3953	3475	3288	3242	2789	2584	2144	1740	1569
2800	400	5140	4612	4405	4100	3604	3410	3362	2892	2679	2224	1805	1627
2900	400	5324	4777	4563	4246	3732	3532	3482	2995	2775	2303	1869	1686
3000	400	5507	4942	4720	4393	3861	3653	3602	3099	2871	2382	1934	1744

TYP 22 K, VK, VKS

Délka [mm]	t_1 / t_2 [°C]	90 / 70			75 / 65			70 / 55			55 / 45		
		t_r [°C]	15	20	22	15	20	22	15	20	22	15	20
400	400	964	866	828	771	679	643	634	547	507	422	344	310
500	400	1204	1083	1035	964	849	804	793	684	634	528	430	388
600	400	1445	1299	1242	1157	1019	965	951	820	761	633	516	466
700	400	1686	1516	1449	1350	1189	1126	1110	957	888	739	602	543
800	400	1927	1732	1656	1542	1358	1286	1269	1094	1014	844	688	621
900	400	2168	1949	1863	1735	1528	1447	1427	1231	1141	950	773	699
1000	400	2409	2165	2070	1928	1698	1608	1586	1367	1268	1055	859	776
1100	400	2650	2382	2276	2121	1868	1769	1744	1504	1395	1161	945	854
1200	400	2891	2598	2483	2314	2038	1930	1903	1641	1522	1267	1031	931
1300	400	3132	2815	2690	2506	2207	2090	2062	1777	1649	1372	1117	1009
1400	400	3373	3031	2897	2699	2377	2251	2220	1914	1775	1478	1203	1087
1500	400	3613	3248	3104	2892	2547	2412	2379	2051	1902	1583	1289	1164
1600	400	3854	3464	3311	3085	2717	2573	2537	2188	2029	1689	1375	1242
1700	400	4095	3681	3518	3278	2887	2734	2696	2324	2156	1794	1461	1319
1800	400	4336	3897	3725	3470	3056	2895	2854	2461	2283	1900	1547	1397
1900	400	4577	4114	3932	3663	3226	3055	3013	2598	2409	2005	1633	1475
2000	400	4818	4330	4139	3856	3396	3216	3172	2734	2536	2111	1719	1552
2100	400	5059	4547	4346	4049	3566	3377	3330	2871	2663	2216	1805	1630
2200	400	5300	4763	4553	4242	3736	3538	3489	3008	2790	2322	1891	1708
2300	400	5541	4980	4760	4435	3905	3699	3647	3145	2917	2428	1977	1785
2400	400	5782	5196	4967	4627	4075	3859	3806	3281	3043	2533	2063	1863
2500	400	6022	5413	5174	4820	4245	4020	3964	3418	3170	2639	2148	1940
2600	400	6263	5629	5381	5013	4415	4181	4123	3555	3297	2744	2234	2018
2700	400	6504	5846	5588	5206	4585	4342	4282	3692	3424	2850	2320	2096
2800	400	6745	6063	5795	5399	4754	4503	4440	3828	3551	2955	2406	2173
2900	400	6986	6279	6002	5591	4924	4663	4599	3965	3678	3061	2492	2251
3000	400	7227	6496	6209	5784	5094	4824	4757	4102	3804	3166	2578	2328

TYP 30 K, VK, VKS

Délka [mm]	t_1 / t_2 [°C]	90 / 70			75 / 65			70 / 55			55 / 45		
		t_r [°C]	15	20	22	15	20	22	15	20	22	15	20
400	400	822	740	707	660	582	552	544	470	436	364	297	269
500	400	1027	925	884	825	728	689	680	587	545	455	372	336
600	400	1233	1110	1061	990	873	827	816	705	654	546	446	403
700	400	1438	1295	1238	1155	1019	965	952	822	764	637	520	470
800	400	1644	1480	1415	1319	1164	1103	1088	940	873	728	594	538
900	400	1849	1664	1592	1484	1310	1241	1224	1057	982	819	669	605
1000	400	2055	1849	1769	1649	1455	1379	1360	1175	1091	910	743	672
1100	400	2260	2034	1946	1814	1601	1517	1496	1292	1200	1001	817	739
1200	400	2466	2219	2122	1979	1746	1655	1632	1410	1309	1092	892	806
1300	400	2671	2404	2299	2144	1892	1793	1768	1527	1418	1183	966	874
1400	400	2877	2589	2476	2309	2037	1930	1904	1645	1527	1274	1040	941
1500	400	3082	2774	2653	2474	2183	2068	2040	1762	1636	1365	1115	1008
1600	400	3288	2959	2830	2639	2328	2206	2176	1880	1745	1456	1189	1075
1700	400	3493	3144	3007	2804	2474	2344	2312	1997	1854	1547	1263	1142
1800	400	3699	3329	3184	2969	2619	2482	2448	2115	1963	1638	1337	1209
1900	400	3904	3514	3361	3134	2765	2620	2584	2232	2073	1729	1412	1277
2000	400	4110	3699	3537	3299	2910	2758	2720	2350	2182	1820	1486	1344
2100	400	4315	3884	3714	3464	3056	2896	2856	2467	2291	1911	1560	1411
2200	400	4521	4069	3891	3629	3201	3034	2992	2585	2400	2002	1635	1478
2300	400	4726	4254	4068	3794	3347	3172	3128	2702	2509	2093	1709	1545
2400	400	4931	4439	4245	3958	3492	3309	3264	2820	2618	2184	1783	1613
2500	400	5137	4624	4422	4123	3638	3447	3400	2937	2727	2275	1858	1680
2600	400	5342	4808	4599	4288	3783	3585	3536	3055	2836	2366	1932	1747
2700	400	5548	4993	4776	4453	3929	3723	3672	3172	2945	2457	2006	1814
2800	400	5753	5178	4952	4618	4074	3861	3808	3290	3054	2548	2080	1881
2900	400	5959	5363	5129	4783	4220	3999	3944	3407	3163	2639	2155	1949
3000	400	6164	5548	5306	4948	4365	4137	4080	3525	3272	2730	2229	2016

TYP 33 K, VK, VKS

Délka [mm]	t_1 / t_2 [°C]	90 / 70			75 / 65			70 / 55			55 / 45		
		t_r [°C]	15	20	22	15	20	22	15	20	22	15	20
400	400	1372	1232	1177	1096	964	913	900	775	718	597	485	438
500	400	1715	1540	1471	1370	1205	1141	1125	968	898	746	606	547
600	400	2058	1848	1765	1644	1446	1369	1350	1162	1077	895	728	657
700	400	2400	2156	2060	1918	1687	1597	1575	1356	1257	1044	849	766
800	400	2743	2464	2354	2192	1928	1825	1800	1550	1436			

TYPY RADIÁTOROV

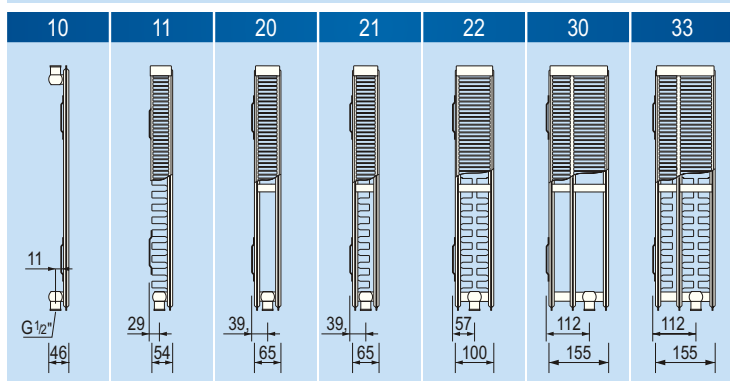

ZÁKLADNÉ TECHNICKÉ ÚDAJE

	Typ radiátora						
	10	11	20	21	22	30	33
M_T^K [kg·m ⁻¹]	18,32	29,47	37,54	42,59	48,30	56,34	73,37
M_T^{VK} [kg·m ⁻¹]	18,70	29,85	37,95	43,00	48,68	56,72	73,75
V_T [dm ³ ·m ⁻¹]	4,30	4,30	8,70	8,70	8,70	13,00	13,00
n [-]	1,3216	1,3237	1,3094	1,3507	1,3348	1,3192	1,3580
H	- výška radiátora						
M_T^K	- hmotnosť telesa radiátora Kompakt						
M_T^{VK}	- hmotnosť telesa radiátora Ventil Kompakt						
V_T	- vodný objem telesa						
n	- exponent charakteristiky panelových radiátorov						

TYP 10 K, VK, VKS

t_1 / t_2 [°C]	90 / 70			75 / 65			70 / 55			55 / 45		
	15	20	22	15	20	22	15	20	22	15	20	22
400	469	422	403	376	332	314	310	268	248	207	169	153
500	586	527	504	470	415	393	387	334	310	259	211	191
600	704	633	605	564	497	471	465	401	372	310	253	229
700	821	738	706	658	580	550	542	468	434	362	295	267
800	938	844	807	752	663	628	620	535	497	414	338	305
900	1055	949	908	846	746	707	697	602	559	466	380	343
1000	1173	1055	1009	940	829	785	775	669	621	517	422	382
1100	1290	1160	1110	1034	912	864	852	736	683	569	464	420
1200	1407	1266	1210	1128	995	943	930	803	745	621	506	458
1300	1524	1371	1311	1222	1078	1021	1007	869	807	673	549	496
1400	1642	1477	1412	1316	1161	1100	1085	936	869	724	591	534
1500	1759	1582	1513	1410	1244	1178	1162	1003	931	776	633	572
1600	1876	1688	1614	1504	1326	1257	1239	1070	993	828	675	610
1700	1993	1793	1715	1598	1409	1335	1317	1137	1055	880	717	649
1800	2111	1899	1816	1693	1492	1414	1394	1204	1117	931	760	687
1900	2228	2004	1916	1787	1575	1492	1472	1271	1179	983	802	725
2000	2345	2110	2017	1881	1658	1571	1549	1338	1241	1035	844	763
2100	2462	2215	2118	1975	1741	1649	1627	1404	1303	1087	886	801
2200	2580	2321	2219	2069	1824	1728	1704	1471	1366	1138	928	839
2300	2697	2426	2320	2163	1907	1807	1782	1538	1428	1190	971	877
2400	2814	2532	2421	2257	1990	1885	1859	1605	1490	1242	1013	916
2500	2931	2637	2522	2351	2073	1964	1937	1672	1552	1294	1055	954
2600	3049	2743	2623	2445	2155	2042	2014	1739	1614	1345	1097	992
2700	3166	2848	2723	2539	2238	2121	2092	1806	1676	1397	1140	1030
2800	3283	2954	2824	2633	2321	2199	2169	1873	1738	1449	1182	1068
2900	3400	3059	2925	2727	2404	2278	2247	1939	1800	1500	1224	1106
3000	3518	3165	3026	2821	2487	2356	2324	2006	1862	1552	1266	1145

TYP 11 K, VK, VKS

t_1 / t_2 [°C]	90 / 70			75 / 65			70 / 55			55 / 45		
	15	20	22	15	20	22	15	20	22	15	20	22
400	761	685	655	610	538	510	503	434	403	336	274	247
500	952	856	818	763	673	637	628	542	503	419	342	309
600	1142	1027	982	916	807	765	754	651	604	503	410	371
700	1332	1198	1146	1068	942	892	880	759	705	587	479	433
800	1523	1370	1310	1221	1076	1019	1005	868	805	671	547	495
900	1713	1541	1473	1373	1211	1147	1131	976	906	755	616	556
1000	1903	1712	1637	1526	1345	1274	1257	1085	1007	839	684	618
1100	2094	1883	1801	1678	1480	1402	1382	1193	1107	923	752	680
1200	2284	2055	1964	1831	1614	1529	1508	1302	1208	1007	821	742
1300	2475	2226	2128	1984	1749	1657	1634	1410	1309	1090	889	804
1400	2665	2397	2292	2136	1883	1784	1759	1519	1409	1174	958	865
1500	2855	2568	2455	2289	2018	1911	1885	1627	1510	1258	1026	927
1600	3046	2739	2619	2441	2152	2039	2011	1735	1610	1342	1094	989
1700	3236	2911	2783	2594	2287	2166	2136	1844	1711	1426	1163	1051
1800	3426	3082	2947	2747	2421	2294	2262	1952	1812	1510	1231	1113
1900	3617	3253	3110	2899	2556	2421	2388	2061	1912	1594	1300	1175
2000	3807	3424	3274	3052	2690	2549	2513	2169	2013	1678	1368	1236
2100												
2200												
2300												
2400												
2500												
2600												
2700												
2800												
2900												
3000												

TYP 20 K, VK, VKS

t_1 / t_2 [°C]	90 / 70			75 / 65			70 / 55			55 / 45		
	15	20	22	15	20	22	15	20	22	15	20	22
400	772	695	665	620	548	519	512	443	411	343	281	254
500	965	869	831	775	685	649	640	553	514	429	351	317
600	1158	1043	998	931	821	779	768	664	617	515	421	381
700	1351	1217	1164	1086	958	908	896	775	719	601	491	444
800	1544	1391	1330	1241	1095	1038	1024	885	822	687	561	508
900	1737	1564	1496	1396	1232	1168	1152	996	925	772	631	571
1000	1930	1738	1663	1551	1369	1298	1280	1107	1028	858	701	635
1100	2123	1912	1829	1706	1506	1428	1408	1217	1131	944	771	698
1200	2316	2086	1995	1861	1643	1557	1536	1328	1233	1030	842	761
1300	2509	2260	2161	2016	1780	1687	1664	1439	1336	1116	912	825
1400	2702	2433	2328	2171	1917	1817	1792	1549	1439	1201	982	888
1500	2895	2607	2494	2326	2054	1947	1920	1660	1542	1287	1052	952
1600	3088	2781	2660	2482	2190	2076	2048	1771	1644	1373	1122	1015
1700	3281	2955	2827	2637	2327	2206	2176	1881	1747	1459	1192	1079
1800	3474	3129	2993	2792	2464	2336	2304	1992	1850	1545	1262	1142
1900	3667	3302	3159	2947	2601	2466	2432	2103	1953	1631	1333	1206
2000	3860	3476	3325	3102	2738	2595	2560	2213	2055	1716	1403	1269
2100	4053	3650	3492	3257	2875	2725	2688	2324	2158	1802	1473	1333
2200	4246	3824	3658	3412	3012	2855	2816	2434	2261	1888	1543	1396
2300	4439	3998	3824	3567	3149	2985	2944	2545	2364	1974	1613	1459
2400	4632	4172	3990	3722	3286	3115	3072	2656	2467	2060	1683	1523
2500	4825	4345	4157	3877	3423	3244	3200	2766	2569	2145	1753	1586
2600	5019	4519	4323	4033	3559	3374	3328	2877	2672	2231	1823	1650
2700	5212	4693	4489	4188	3696	3504	3456	2988	2775	2317	1894	1713
2800	5405	4867	4655	4343	3833	3634	3584	3098	2878	2403	1964	1777
2900	5598	5041	4822	4498	3970	3763	3712	3209	2980	2489	2034	1840
3000	5791	5214	4988	4653	4107	3893	3840	3320	3083	2575	2104	1904

TYP 21 K, VK, VKS

t_1 / t_2 [°C]	90 / 70			75 / 65			70 / 55			55 / 45		
	15	20	22	15	20	22	15	20	22	15	20	22
400	1019	915	874	813	715	677	667	574	532	442	359	324
500	1274	1144	1092	1017	894	846	834	718	665	552	448	404
600	1529	1372	1311	1220	1073	1015	1001	861	798	663	538	485
700	1784	1601	1529	1424	1252	1184	1168	1005	931	773	628	566
800	2039	1830	1748	1627	1430	1354	1335	1148	1064	884	717	647
900	2294	2059	1966	1830	1609	1523	1501	1292	1197	994	807	728
1000	2548	2287	2185	2034	1788	1692	1668	1436	1330	1104	897	809
1100	2803	2516	2403	2237	1967	1861	1835	1579	1463	1215	987	890
1200	3058	2745	2622	2440	2146	2030	2002	1723	1596	1325	1076	971
1300	3313	2973	2840	2644	2324	2200	2169	1866	1729	1436	1166	1052
1400	3568	3202	3059	2847	2503	2369	2336	2010	1862	1546	1256	1132
1500	3823	3431	3277	3050	2682	2538	2502	2153	1995	1657	1345	1213
1600	4077	3660	3496	3254	2861	2707	2669	2297	2128	1767	1435	1294
1700	4332	3888	3714	3457	3040	2877	2836	2441	2261	1878	1525	1375
1800	4587	4117	3933	3661	3218	3046	3003	2584	2394	1988	1614	1456
1900	4842	4346	4151	3864	3397	3215	3170	2728	2527	2098	1704	1537
2000	5097	4575	4370	4067	3576	3384	3337	2871	2660	2209	1794	1618
2100	5352	4803	4588	4271	3755	3553	3503	3015	2793	2319	1883	1699
2200	5607	5032	4807	4474	3934	3723	3670	3158	2926	2430	1973	1780
2300	5861	5261	5025	4677	4112	3892	3837	3302	3059	2540	2063	1860
2400	6116	5489	5244	4881	4291	4061	4004	3445	3192	2651	2152	1941
2500	6371	5718	5462	5084	4470	4230	4171	3589	3325	2761	2242	2022
2600	6626	5947	5681	5287	4649	4399	4338	3733	3459	2872	2332	2103
2700	6881	6176	5899	5491	4828	4569	4504	3876	3592	2982	2421	2184
2800	7136	6404	6118	5694	5006	4738	4671	4020	3725	3092	2511	2265
2900	7390	6633	6336	5898	5185	4907	4838	4163	3858	3203	2601	2346
3000	7645	6862	6555	6101	5364	5076	5005	4307	3991	3313	2691	2427

TYP 22 K, VK, VKS

t_1 / t_2 [°C]	90 / 70			75 / 65			70 / 55			55 / 45		
	15	20	22	15	20	22	15	20	22	15	20	22
400	1333	1198	1145	1067	939	889	877	756	701	583	475	429
500	1666	1497	1431	1333	1174	1112	1096	945	876	729	594	536
600	2000	1797	1717	1600	1409	1334	1316	1134	1052	875	712	643
700	2333	2096	2004	1867	1644	1556	1535	1323	1227	1021	831	751
800	2666	2396	2290	2133	1878	1779	1754	1512	1402	1167	950	858
900	2999	2695	2576	2400	2113	2001	1973	1701	1578	1313	1069	965
1000	3333	2995	2862	2667	2348	2223	2193	1890	1753	1459	1187	1072
1100	3666	3294	3149	2933	2583	2446	2412	2079	1928	1604	1306	1179
1200	3999	3594	3435	3200	2818	2668	2631	2268	2103	1750	1425	1287
1300	4332	3893	3721	3467	3052	2891	2850	2457	2279	1896	1544	1394
1400	4666	4193	4007	3733	3287	3113	3070	2646	2454	2042	1662	1501
1500	4999	4492	4294	4000	3522	3335	3289	2835	2629	2188	1781	1608
1600	5332	4792	4580	4266	3757	3558	3508	3024	2805	2334	1900	1716
1700	5666	5091	4866	4533	3992	3780	3727	3213	2980	2480	2018	1823
1800	5999	5391	5152	4800	4226	4002	3947	3402	3155	2625	2137	1930
1900	6332	5690	5439	5066	4461	4225	4166	3591	3331	2771	2256	2037
2000	6665	5990	5725	5333	4696	4447	4385	3780	3506	2917	2375	2144
2100	6999	6289	6011	5600	4931	4669	4605	3969	3681	3063	2493	2252
2200	7332	6589	6297	5866	5166	4892	4824	4158	3856	3209	2612	2359
2300	7665	6888	6584	6133	5400	5114	5043	4347	4032	3355	2731	2466
2400	7998	7188	6870	6400	5635	5336	5262	4536	4207	3501	2850	2573
2500	8332	7487	7156	6666	5870	5559	5482	4725	4382	3646	2968	2680
2600	8665	7787	7442	6933	6105	5781	5701	4914	4558	3792	3087	2788
2700	8998	8086	7729	7200	6340	6003	5920	5103	4733	3938	3206	2895
2800	9331	8386	8015	7466	6574	6226	6139	5292	4908	4084	3325	3002
2900	9665	8685	8301	7733	6809	6448	6359	5481	5083	4230	3443	3109
3000	9998	8985	8587	8000	7044	6670	6578	5670	5259	4376	3562	3217

TYP 30 K, VK, VKS

t_1 / t_2 [°C]	90 / 70			75 / 65			70 / 55			55 / 45		
	15	20	22	15	20	22	15	20	22	15	20	22
400	1153	1038	992	925	816	773	763	659	611	510	416	376
500	1442	1297	1241	1157	1020	967	953	823	764	637	520	470
600	1730	1557	1489	1388	1224	1160	1144	988	917	765	624	564
700	2019	1816	1737	1619	1428	1353	1335	1152	1070	892	728	658
800	2307	2076	1985	1851	1632	1546	1525	1317	1223	1019	832	752
900	2595	2335	2233	2082	1836	1740	1716	1482	1375	1147	936	846
1000	2884	2595	2481	2313	2040	1933	1907	1646	1528	1274	1040	940
1100	3172	2854	2729	2545	2244	2126	2097	1811	1681	1402	1144	1034
1200	3460	3114	2977	2776	2448	2320	2288	1976	1834	1529	1248	1128
1300	3749	3373	3226	3007	2652	2513	2478	2140	1987	1657	1352	1222
1400	4037	3633	3474	3239	2856	2706	2669	2305	2139	1784	1456	1316
1500	4325	3892	3722	3470	3060	2900	2860	2470	2292	1912	1560	1410
1600	4614	4152	3970	3701	3264	3093	3050	2634	2445	2039	1664	1504
1700	4902	4411	4218	3933	3468	3286	3241	2799	2598	2166	1768	1598
1800	5191	4670	4466	4164	3672	3479	3432	2963	2751	2294	1872	1692
1900	5479	4930	4714	4395	3876	3673	3622	3128	2904	2421	1976	1786
2000	5767	5189	4962	4627	4080	3866	3813	3293	3056	2549	2080	1880
2100	6056	5449	5211	4858	4284	4059	4004	3457	3209	2676	2184	1974
2200	6344	5708	5459	5089	4488	4253	4194	3622	3362	2804	2288	2068
2300	6632	5968	5707	5321	4692	4446	4385	3787	3515	2931	2392	2162
2400	6921	6227	5955	5552	4896	4639	4576	3951	3668	3058	2496	2256
2500	7209	6487	6203	5783	5100	4833	4766	4116	3820	3186	2600	2350
2600	7498	6746	6451	6015	5304	5026	4957	4280	3973	3313	2704	2444
2700	7786	7006	6699	6246	5508	5219	5148	4445	4126	3441	2808	2538
2800	8074	7265	6947	6477	5712	5413	5338	4610	4279	3568	2912	2632
2900	8363	7525	7196	6709	5916	5606	5529	4774	4432	3696	3016	2726
3000	8651	7784	7444	6940	6120	5799	5720	4939	4585	3823	3120	2820

TYP 33 K, VK, VKS

t_1 / t_2 [°C]	90 / 70			75 / 65			70 / 55			55 / 45		
	15	20	22	15	20	22	15	20	22	15	20	22
400	1866	1674	1599	1487	1307	1236	1219	1048	971	805	653	589
500	2333	2092	1998	1859	1634	1545	1524	1310	1213	1006	816	736
600	2799	2511	2398	2231	1960	1854	1828	1572	1456	1208	980	883
700	3266	2929	2798	2603	2287	2164	2133	1834	1699	1409	1143	1030
800	3732	3348	3197	2975	2614	2473	2438	2096	1941	1610	1306	1177
900	4199	3766	3597	3347	2940	2782	2742	2358	2184	1811	1469	1324
1000	4665	4185	3997	3718	3267	3091	3047	2620	2427	2013	1633	1472
1100	5132	4603	4396	4090	3594	3400	3352	2882	2669	2214	1796	1619
1200	5598	5022	4796	4462	3920	3709	3657	3144	2912	2415	1959	1766
1300	6065	5440	5195	4834	4247	4018	3961	3406	3155	2617	2122	1913
1400	6531	5859	5595	5206	4574	4327	426					

RADIÁTORY S HLADKÝM ČELNÝM PANELOM (TYP PLAN)

TYP 10 PLAN

H [mm]	M_T^K [kg.m ⁻¹]	M_T^{VK} [kg.m ⁻¹]	V_T [dm ³ .m ⁻¹]	n	Φ_n [W.m ⁻¹] pre $t_1/t_2; t_r = 20^\circ\text{C}$			
					90/70	75/65	70/55	55/45
300	9,38	9,59	1,81	1,2690	398	316	257	165
400	12,10	12,34	2,24	1,2674	502	399	325	209
500	14,98	15,25	2,67	1,2657	600	476	388	249
550	16,55	-	2,80	1,2948	649	515	419	270
600	17,78	18,08	3,10	1,2649	690	548	446	287
900	26,20	26,58	4,30	1,2641	927	735	597	383

TYP 11 PLAN

H [mm]	M_T^K [kg.m ⁻¹]	M_T^{VK} [kg.m ⁻¹]	V_T [dm ³ .m ⁻¹]	n	Φ_n [W.m ⁻¹] pre $t_1/t_2; t_r = 20^\circ\text{C}$			
					90/70	75/65	70/55	55/45
300	13,22	13,44	1,81	1,2790	639	506	411	263
400	17,20	17,44	2,24	1,2797	788	624	507	325
500	21,43	21,70	2,67	1,2804	936	741	602	385
550	-	-	-	-	-	-	-	-
600	25,20	25,50	3,10	1,2811	1086	860	698	447
900	37,34	37,72	4,30	1,2732	1560	1237	1006	646

TYP 20W PLAN (šírka = 100 mm)

H [mm]	M_T^K [kg.m ⁻¹]	M_T^{VK} [kg.m ⁻¹]	V_T [dm ³ .m ⁻¹]	n	Φ_n [W.m ⁻¹] pre $t_1/t_2; t_r = 20^\circ\text{C}$			
					90/70	75/65	70/55	55/45
300	16,68	16,88	3,50	1,3088	710	559	452	287
400	21,20	21,44	4,37	1,3033	902	711	575	365
500	25,68	25,95	5,23	1,2977	1082	854	692	440
550	28,40	-	5,30	1,2909	1174	928	752	480
600	30,70	31,01	6,10	1,2918	1252	989	802	511
900	45,42	45,83	8,70	1,2659	1708	1356	1104	710

TYP 20 PLAN (šírka = 65 mm)

H [mm]	M_T^K [kg.m ⁻¹]	M_T^{VK} [kg.m ⁻¹]	V_T [dm ³ .m ⁻¹]	n	Φ_n [W.m ⁻¹] pre $t_1/t_2; t_r = 20^\circ\text{C}$			
					90/70	75/65	70/55	55/45
300	16,68	16,88	3,50	1,2547	642	511	416	269
400	21,20	21,44	4,37	1,2595	811	645	525	339
500	25,68	25,95	5,23	1,2642	972	772	629	405
550	28,40	-	5,30	1,2981	1056	839	683	439
600	30,70	31,01	6,10	1,2668	1127	894	727	468
900	45,42	45,83	8,70	1,2690	1567	1237	1002	638

TYP 21 PLAN

H [mm]	M_T^K [kg.m ⁻¹]	M_T^{VK} [kg.m ⁻¹]	V_T [dm ³ .m ⁻¹]	n	Φ_n [W.m ⁻¹] pre $t_1/t_2; t_r = 20^\circ\text{C}$			
					90/70	75/65	70/55	55/45
300	17,59	17,79	3,50	1,3015	883	697	564	358
400	22,96	23,20	4,37	1,3114	1086	855	691	438
500	28,36	28,63	5,23	1,3213	1280	1006	812	512
550	31,85	-	5,30	1,3640	1382	1085	875	551
600	33,75	34,06	6,10	1,3266	1469	1152	928	584
900	50,47	50,88	8,70	1,3312	2010	1575	1268	796

TYP 22 PLAN

H [mm]	M_T^K [kg.m ⁻¹]	M_T^{VK} [kg.m ⁻¹]	V_T [dm ³ .m ⁻¹]	n	Φ_n [W.m ⁻¹] pre $t_1/t_2; t_r = 20^\circ\text{C}$			
					90/70	75/65	70/55	55/45
300	19,76	19,95	3,50	1,3036	1157	913	739	469
400	26,49	26,72	4,37	1,3121	1454	1146	927	588
500	31,98	32,23	5,23	1,3207	1732	1364	1103	699
550	36,05	-	5,30	1,3290	1875	1477	1193	756
600	38,00	38,28	6,10	1,3292	1995	1570	1268	803
900	56,17	56,56	8,70	1,3321	2708	2129	1718	1085

TYP 30 PLAN

H [mm]	M_T^K [kg.m ⁻¹]	M_T^{VK} [kg.m ⁻¹]	V_T [dm ³ .m ⁻¹]	n	Φ_n [W.m ⁻¹] pre $t_1/t_2; t_r = 20^\circ\text{C}$			
					90/70	75/65	70/55	55/45
300	24,23	24,42	5,20	1,2911	993	785	636	406
400	30,89	31,11	6,53	1,2930	1243	982	796	507
500	37,55	37,80	7,87	1,2950	1484	1172	949	605
550	40,80	-	8,15	1,2960	1611	1272	1031	656
600	44,21	44,50	9,20	1,2969	1719	1357	1099	700
900	64,22	64,60	13,00	1,3116	2418	1904	1538	974

TYP 33 PLAN

H [mm]	M_T^K [kg.m ⁻¹]	M_T^{VK} [kg.m ⁻¹]	V_T [dm ³ .m ⁻¹]	n	Φ_n [W.m ⁻¹] pre $t_1/t_2; t_r = 20^\circ\text{C}$			
					90/70	75/65	70/55	55/45
300	27,94	26,13	5,20	1,3022	1648	1300	1052	668
400	37,47	37,69	6,53	1,3070	2073	1634	1321	838
500	45,07	45,33	7,87	1,3117	2477	1951	1576	998
550	50,90	-	8,15	1,3446	2689	2116	1709	1081
600	53,97	54,25	9,20	1,3143	2866	2255	1820	1151
900	81,25	81,63	13,00	1,3165	3969	3112	2505	1574

RADIÁTORY DO PRIESTOROV SO ZVÝŠENÝMI POŽIADAVKAMI NA HYGIENU

TYP 20W K, VK, VKS (šírka = 100 mm)

H [mm]	M_T^K [kg.m ⁻¹]	M_T^{VK} [kg.m ⁻¹]	V_T [dm ³ .m ⁻¹]	n	Φ_n [W.m ⁻¹] pre $t_1/t_2; t_r = 20^\circ\text{C}$			
					90/70	75/65	70/55	55/45
300	14,06	14,25	3,50	1,2897	774	612	496	317
400	17,70	17,94	4,37	1,2953	974	769	623	397
500	21,30	21,57	5,23	1,3010	1166	920	745	473
550	23,55	-	5,30	1,3037	1262	995	805	511
600	25,45	25,76	6,10	1,3066	1355	1068	864	548
900	37,54	37,95	8,70	1,3162	1907	1500	1211	766

LEGENDA

- H [mm] - výška radiátora
- M_T^K [kg.m⁻¹] - hmotnosť telesa radiátora Kompakt
- M_T^{VK} [kg.m⁻¹] - hmotnosť telesa radiátora Ventil Kompakt
- V_T [dm³.m⁻¹] - vodný objem telesa
- n [-] - exponent charakteristiky panelových radiátorov
- Φ_n [W.m⁻¹] - normovaný tepelný výkon
- t_1 [°C] - vstupná teplota vykurovacieho média
- t_2 [°C] - výstupná teplota vykurovacieho média
- t_r [°C] - pri referenčnej teplote ovzdušia ($t_r = 20^\circ\text{C}$)

PREPOČÍTACIE FAKTORY "F" PRE INÉ PREVÁDZKOVÉ PODMIENKY

t ₁ [°C]	t ₂ [°C]	Teplota vzduchu v miestnosti t _r [°C]							n = 1,3331
		10	12	15	18	20	22	24	
110	90	0,4568	0,4707	0,4929	0,5171	0,5344	0,5528	0,5722	EN 442: t ₁ [°C] = 75 t ₂ [°C] = 65 t _r [°C] = 20
110	80	0,4929	0,5088	0,5344	0,5624	0,5824	0,6038	0,6266	
105	90	0,4742	0,4891	0,5129	0,5389	0,5575	0,5773	0,5983	
105	80	0,5129	0,5300	0,5575	0,5877	0,6094	0,6325	0,6573	
105	70	0,5575	0,5773	0,6094	0,6447	0,6703	0,6977	0,7271	
100	90	0,4929	0,5088	0,5344	0,5624	0,5824	0,6038	0,6266	
100	80	0,5344	0,5528	0,5824	0,6150	0,6386	0,6637	0,6907	
100	70	0,5824	0,6038	0,6386	0,6770	0,7049	0,7348	0,7671	
95	80	0,5824	0,6038	0,6386	0,6770	0,7049	0,7348	0,7671	
95	70	0,6094	0,6325	0,6703	0,7122	0,7427	0,7756	0,8112	
95	60	0,6703	0,6977	0,7427	0,7930	0,8300	0,8701	0,9138	
90	80	0,5824	0,6038	0,6386	0,6770	0,7049	0,7348	0,7671	
90	75	0,6094	0,6325	0,6703	0,7122	0,7427	0,7756	0,8112	
90	70	0,6386	0,6637	0,7049	0,7507	0,7842	0,8205	0,8598	
90	65	0,6703	0,6977	0,7427	0,7930	0,8300	0,8701	0,9138	
90	60	0,7049	0,7348	0,7842	0,8397	0,8807	0,9253	0,9739	
90	55	0,7427	0,7756	0,8300	0,8915	0,9370	0,9868	1,0414	
90	50	0,7842	0,8205	0,8807	0,9491	1,0000	1,0559	1,1176	
85	75	0,6386	0,6637	0,7049	0,7507	0,7842	0,8205	0,8598	
85	70	0,6703	0,6977	0,7427	0,7930	0,8300	0,8701	0,9138	
85	65	0,7049	0,7348	0,7842	0,8397	0,8807	0,9253	0,9739	
85	60	0,7427	0,7756	0,8300	0,8915	0,9370	0,9868	1,0414	
85	55	0,7842	0,8205	0,8807	0,9491	1,0000	1,0559	1,1176	
85	50	0,8300	0,8701	0,9370	1,0135	1,0708	1,1340	1,2040	
80	70	0,7049	0,7348	0,7842	0,8397	0,8807	0,9253	0,9739	
80	65	0,7427	0,7756	0,8300	0,8915	0,9370	0,9868	1,0414	
80	60	0,7842	0,8205	0,8807	0,9491	1,0000	1,0559	1,1176	
80	55	0,8300	0,8701	0,9370	1,0135	1,0708	1,1340	1,2040	
80	50	0,8807	0,9253	1,0000	1,0860	1,1508	1,2227	1,3029	
75	65	0,7842	0,8205	0,8807	0,9491	1,0000	1,0559	1,1176	
75	60	0,8300	0,8701	0,9370	1,0135	1,0708	1,1340	1,2040	
75	55	0,8807	0,9253	1,0000	1,0860	1,1508	1,2227	1,3029	
75	50	0,9370	0,9868	1,0708	1,1681	1,2419	1,3243	1,4168	
70	60	0,8807	0,9253	1,0000	1,0860	1,1508	1,2227	1,3029	
70	55	0,9370	0,9868	1,0708	1,1681	1,2419	1,3243	1,4168	
70	50	1,0000	1,0559	1,1508	1,2617	1,3465	1,4417	1,5495	
70	45	1,0708	1,1340	1,2419	1,3692	1,4674	1,5787	1,7055	
70	40	1,1508	1,2227	1,3465	1,4939	1,6088	1,7401	1,8913	
65	55	1,0000	1,0559	1,1508	1,2617	1,3465	1,4417	1,5495	
65	50	1,0708	1,1340	1,2419	1,3692	1,4674	1,5787	1,7055	
65	45	1,1508	1,2227	1,3465	1,4939	1,6088	1,7401	1,8913	
65	40	1,2419	1,3243	1,4674	1,6399	1,7758	1,9328	2,1156	
60	55	1,0708	1,1340	1,2419	1,3692	1,4874	1,5787	1,7055	
60	50	1,1508	1,2227	1,3465	1,4939	1,6088	1,7401	1,8913	
60	45	1,2419	1,3243	1,4674	1,6399	1,7758	1,9328	2,1156	
60	40	1,3465	1,4417	1,6088	1,8129	1,9758	2,1662	2,3911	
55	50	1,2419	1,3243	1,4674	1,6399	1,7758	1,9328	2,1156	
55	45	1,3465	1,4417	1,6088	1,8129	1,9758	2,1662	2,3911	
55	40	1,4674	1,5787	1,7758	2,0206	2,2188	2,4538	2,7361	
55	35	1,6088	1,7401	1,9758	2,2738	2,5194	2,8156	3,1787	
55	30	1,7758	1,9328	2,2188	2,5882	2,8994	3,2824	3,7638	
45	40	1,7758	1,9328	2,2188	2,5882	2,8994	3,2824	3,7638	
45	35	1,9758	2,1662	2,5194	2,9875	3,3923	3,9039	4,5676	
45	30	2,2188	2,4538	2,8994	3,5087	4,0532	4,7650	5,7286	
40	35	2,2188	2,4538	2,8994	3,5087	4,0532	4,7650	5,7286	
40	30	2,5194	2,8156	3,3923	4,2129	4,9779	6,0242	7,5269	
40	25	2,8994	3,2824	4,0532	5,2081	6,3476	8,0085	10,6142	

PRÍKLAD

Hľadáme prednastavenie ventilu pre radiátor KORAD typ 21, výška = 600 mm, dĺžka = 1 000 mm v sústave s projektovaným poklesom teploty vody 90 / 70 °C a tlakovej strate 3 kPa.

Dané:

- tepelný výkon $\Phi = 2\,165\text{ W}$
- pokles teploty vody $\Delta t = 20\text{ K [90/70}^\circ\text{C]}$
- tlaková strata $\Delta p = 3\text{ kPa}$
- špecifické teplo vody $C = 4186\text{ m}^2 \cdot \text{s}^{-2} \cdot \text{K}^{-1}$
- hmotnostný prietok $M_w [\text{kg} \cdot \text{h}^{-1}]$

RIEŠENIE

$$M_w = \frac{\Phi}{C \cdot \Delta t} = \frac{2165}{4186 \cdot 20} \cdot 3600 \approx 93 [\text{kg} \cdot \text{h}^{-1}]$$

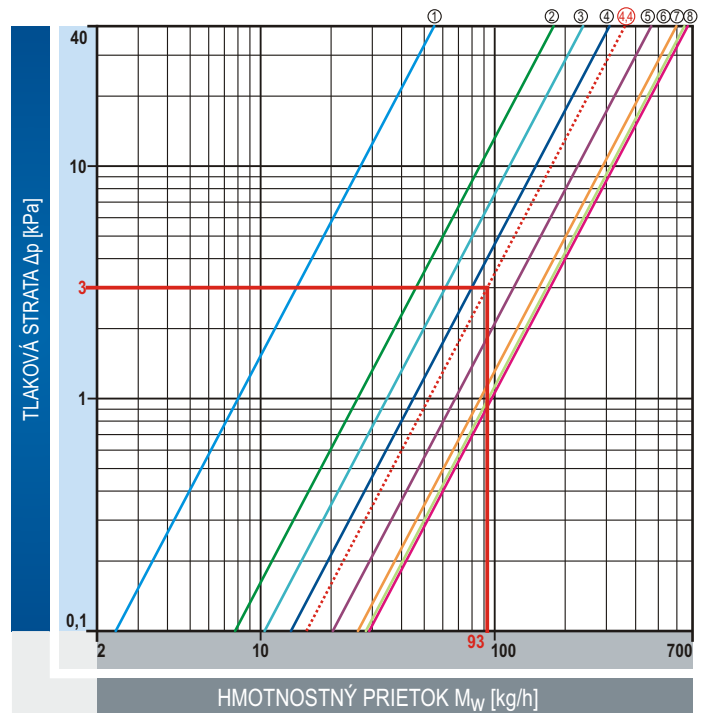

Ventilová vložka Heimeier 4360 s ôsmymi základnými polohami a s možnosťou nastavenia medzipolôh. Táto vložka je štandardne montovaná do radiátorov Korad Vetil Kompakt, ako súčasť dodávky.

DIAGRAM $\Delta p - M_w - k_v$ 

Z diagramu $\Delta p - M_w - k_v$ pre dané a vypočítané hodnoty odpočítame prednastavenie ventilu: **4,4**.

PREPOČET VÝKONU RADIÁTOROV PRE INÉ PREVÁDZKOVÉ PODMIENKY

POSTUP VÝPOČTU

Tepelné výkony vyhrievacích telies podľa EN 442 sú platné pri základných prevádzkových podmienkach stanovených normou:

- vstupná teplota vody $t_1 = 75^\circ\text{C}$
- výstupná teplota vody $t_2 = 65^\circ\text{C}$
- vzťažná teplota vzduchu $t_r = 20^\circ\text{C}$

Pre iné prevádzkové podmienky je nutné vykonať prepočet tepelného výkonu podľa vzťahu: $\Phi = \Phi_c \cdot f$

kde: Φ [W] - vypočítaný tepelný výkon vyhrievacieho telesa pri prevádzkových podmienkach podľa EN 442.

Φ_c [W] - vypočítaný tepelný výkon (tepelná strata) vyhrievacieho telesa pri iných prevádzkových podmienkach ako určuje EN 442

f - prepočítavací faktor pre iné prevádzkové podmienky podľa uvedenej tabuľky

Z tabuliek tepelné výkony pre teplotné podmienky 76/65/20 °C nájdeme pre vypočítanú hodnotu Φ vhodné vyhrievacie teleso.

PRÍKLAD

Je potrebné navrhnuť vyhrievacie teleso KORAD do miestnosti s vnútornou výpočtovou teplotou vzduchu 18 °C a s vykurovaciou sústavou prevádzkovanou s teplotným spádom 70/40 °C:

- vstupná teplota vody $t_1 = 70^\circ\text{C}$
- výstupná teplota vody $t_2 = 40^\circ\text{C}$
- vzťažná teplota vzduchu $t_r = 18^\circ\text{C}$

Tepelná strata vypočítaná pre základné prevádzkové podmienky podľa normy EN442 pre 75/65/20 °C je 1137 W.

RIEŠENIE

Pre prevádzkové podmienky 70/40/18 °C nájdeme v tabuľke hodnotu koeficientu „f“: $f = 1,4939$

$$\text{Výpočet: } \Phi = 1137 \times 1,4939 = 1699\text{ W}$$

Pre vypočítanú hodnotu Φ nájdeme v tabuľkách tepelných výkonov (strana 12 - 22) pre teplotný spád 75/65/20 °C vhodné vyhrievacie teleso s najbližším tepelným výkonom. Z katalógu panelových radiátorov KORAD je možné vybrať jeden z nasledujúcich radiátorov:

Typ 11K, 11VK, VKS	600 x 1800	1728 W
Typ 20K, 20VK, VKS	600 x 1600	1632 W
Typ 21K, 21VK, VKS	600 x 1300	1673 W
Typ 22K, 22VK, VKS	600 x 1000	1698 W
Typ 33K, 33VK, VKS	600 x 700	1687 W

Z praktických dôvodov sme vyhľadávanie obmedzili len na vyhrievacie telesá o výške H = 600 mm.

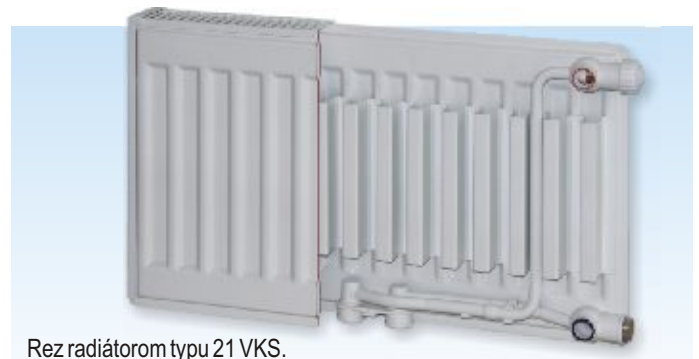

Rez radiátorom typu 21 VKS.

ZNAČENIE PANELOVÝCH RADIÁTOROV

Každý radiátor KORAD je označený štítkom s čiarovým kódom, ktorý obsahuje dátum výroby, prevádzkový tlak a typ radiátora. Pod ochrannú fóliu zabaleného radiátora sa vkladá „TYPE“ štítk s označením typu a rozmeru radiátora. Na zadnej strane „TYPE“ štítku sú uvedené záručné podmienky.

Radiátor sa označuje číselným kódom alebo slovnou.

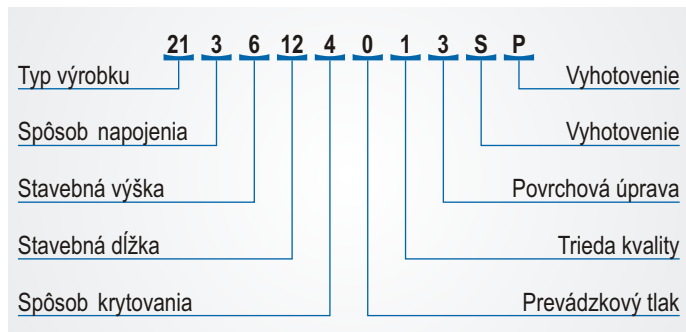

PŘÍKLAD OBJEDNÁVKY

2136124013SP - Panelový radiátor typ 21 VKS (Ventil Kompakt, stredové napojenie s ventilovou vložkou na pravej strane), výška 600 mm, dĺžka 1200 mm, s hladkou čelnou plochou.

2246122013 - Panelový radiátor 22K (Kompakt), výška 600 mm, dĺžka 1200 mm.

ČÍSELNÍK RADIÁTOROV

Číslo	Popis	Označenie
1. + 2.	Typ výroby	1. pozícia: počet panelov 2. pozícia: počet konvektorov
3.	Spôsob napojenia	4- typ K 3- typ VKP (pravý) 5- typ VKL (ľavý) 6- typ VK bez závesných držiakov 8- typ K bez závesných držiakov
4.	Stavebná výška	3- 300 mm 4- 400 mm 5- 500 mm 1- 550 mm 6- 600 mm 9- 900 mm
5.+ 6.	Stavebná dĺžka	04- 30 - (400 - 3000 mm) napr. 12 = stavebná dĺžka 1200 mm
7.	Spôsob krytovania	0- bez krytov 2- s krytmi 4- s krytmi (úzky typ 20, 21)
8.	Prevádzkový tlak	0- 1 MPa 6- 0,6 MPa
9.	Trieda kvality	1- I. trieda 2- II. trieda
10.	Farba	3- RAL 9010 0- čierna 2- základný náter 8- iná RAL
Doplňujúce údaje (uvádzane podľa potreby)		
11.	Vyhotovenie	S- stredové napojenie U- úzky (typ 20, 21 = 65mm) G- posunuté závesné držiaky 0- pomocný znak
12.	Vyhotovenie	P- hladká čelná plocha

FAREBNÉ ODTIENE POVRCHU RADIÁTOROV

Zobrazené farebné odtiene sú len orientačné



Slovenská republika

Výrobca:
U. S. Steel Košice, s.r.o.
Slovenská republika

Predajca:
ZANZI s.r.o.
Areál Haniska